

Small Circular Bollard Grip (QC-E04)

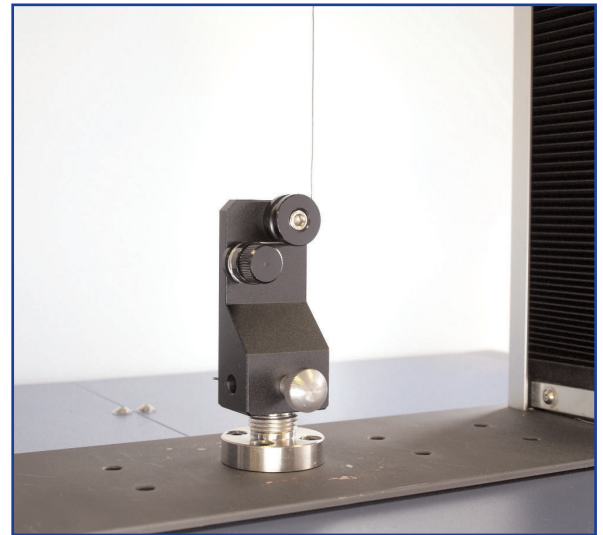

Testing cotton yarn

Description

These small circular bollard grips are made from aluminium and are designed for testing delicate, flexible samples such as fine threads, wires and yarns, which may break easily when clamped. The sample is wrapped around the bollard and the free end is clamped tightly in place using a pair of friction washers and a thumbscrew. The bollard has a single 5mm (0.197") wide smooth groove to align the sample centrally and has a diameter of 20mm (0.79") around which it can be wound.

Applications

Used for tensile testing of:

- fibres
- filaments
- threads
- yarns
- twines
- fine wires

Specifications

Maximum Capacity	Minimum Load (to maintain tension)	Roller Diameter	Weight	Length
100N (10kgf, 22lbf)	50gf	20mm (0.79")	210g (0.46lbs)	102.5mm (4")

*Q = Quick-interchange via 8mm Ø pin

ACCESSORY PART NO. 432-270

Dimensions mm (inch)

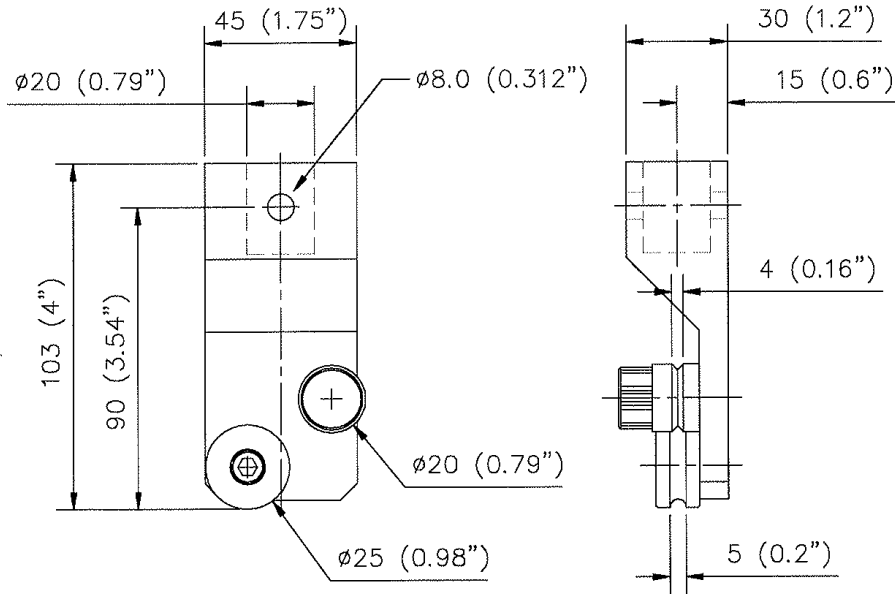

Adaptors

To fit to:	Adaptor Type and (Part Number)**
Loadcells	
XLC-T / ILC-T 25kN	Type C (432-284) and Type G (432-288)
XLC-T / ILC-T 10kN, XLC-S / ILC-S 2500N, 5000N	Type C (432-284) and Type F (432-287)
XLC-S / ILC-S 1000N	Type C (432-284) and Type E (432-286)
XLC-S / ILC-S 100N, 200N, 500N	Type C (432-284) and Type D (432-285)
Force Gauge with 5/16 UNC Thread	Type A (432-282)
ILC / Force Gauge 10/32 UNF Thread	Type A (432-282) and 10/32 to 5/16 - F to F (ACC008-27)
Test Stands	
MultiTest 10kN / 25kN	Type C (432-284)
MultiTest 5kN	Type A (432-282)

** For further information please see Adaptor Datasheet 431-354-1-1



S.I. Instruments

256 South Rd. Hilton
South Australia 5033
Ph (08) 8352 5511

info@si-instruments.com
www.si-instruments.com

DISTRIBUTOR STAMP

431-354-10-1

Mecmesin reserves the right to alter equipment specifications without prior notice.

Head Office

Mecmesin Limited
Newton House, Spring
Copse Business Park,
Slinfold, West Sussex,
RH13 OSZ, UK

e. sales@mecmesin.com
t. +44 (0) 1403 799979
f. +44 (0) 1403 799975

North America

Mecmesin Corporation
45921 Maries Road,
Suite 120, Sterling
Virginia 20166,
U.S.A.

e. info@mecmesincorp.com
t. +1 703 433 9247
f. +1 703 444 9860

Asia

Mecmesin Asia Co. Ltd
91/1 Chaiyo Building, 11th Floor,
Room 1103, Rama 9 Road, Huaykwang,
Bangkok, 10310,
Thailand

e. sales@mecmesinasia.com
t. +66 2 247 46 81
f. +66 2 247 46 82

China

Mecmesin (Shanghai) Pte Ltd
Unit 18D, SiChuang Building No3,
No 600, Tian Shan Road,
Changning District, Shanghai,
People's Republic of China

e. sales@mecmesin-china.com
t. +86 21 6233 3459
f. +86 21 6233 3479