

Operation Manual BA1552_2e_A400_V0200_Interface_EN

Multi-channel force/displacement-measuring device **DMF-P A400** *Interface*

Version of date: 2006-02-07



Dr. Staiger, Mohilo+Co GmbH
Maierhofstraße 35, D-73547 Lorch
Telefon +49 7172 184-0,
Telefax +49 7172 184-500
E-Mail: info@staiger-mohilo.de
Internet: [http:// www.staiger-mohilo.de](http://www.staiger-mohilo.de)

Operating instructions 1552 / 2e



Important note:

The contents of this operation manual are copyright. This particularly applies to the translation of material as well as its reproduction, the extraction of diagrams, transmission by radio, reproduction by photomechanical or similar means and storage in data processing equipment. This also applies to the use of extracts from the manual.

The authors have taken great care and used effective monitoring processes in compiling all the technical specifications and programs in this document. Nevertheless, errors may occur, therefore Staiger, Mohilo must point out that no warranty or any liability can be assumed for the consequences arising from incorrect information, accidental damage or consequential damage.

Furthermore no warranty can be assumed for the material, the quality and the suitability for a particular purpose. The contents are subject to error and technical change. The authors would appreciate if they could be informed about any possible errors.

1. List of contents

| | | |
|---------|--|----|
| 1. | List of contents..... | 3 |
| 2. | Note on safety..... | 3 |
| 3. | Description of the system | 4 |
| 3.1. | General function | 4 |
| 3.2. | Scope of delivery | 5 |
| 3.3. | Front view and description of positions..... | 6 |
| 3.4. | Rear view and description of positions | 7 |
| 4. | Measurement..... | 8 |
| 4.1. | Standard sequence of measuring cycle..... | 8 |
| 5. | Activation and signals..... | 9 |
| 5.1. | Schematic diagram | 9 |
| 5.2. | Parallel interface | 10 |
| 5.3. | Profibus | 11 |
| 5.4. | Interfaces | 12 |
| 5.4.1. | Voltage supply | 13 |
| 5.4.2. | LAN (Ethernet) | 13 |
| 5.4.3. | Keyboard..... | 13 |
| 5.4.4. | Serial interface RS-232 (COM1) | 14 |
| 5.4.5. | Serial interface RS-232 (COM2) | 14 |
| 5.4.6. | LPT (Printer interface parallel) | 15 |
| 5.4.7. | Profibus DP (Option)..... | 15 |
| 5.4.8. | Fieldbus | 15 |
| 5.4.9. | Measuring module Y (force) active 0 ... $\pm 10V$ | 16 |
| 5.4.10. | Measuring module Y (force) strain gage..... | 17 |
| 5.4.11. | Measuring module Y (force) Piezo | 18 |
| 5.4.12. | Measuring module X (displacement) active 0 ... $\pm 10V$ | 19 |
| 5.4.13. | Measuring module X (displacement) resistive | 20 |
| 5.4.14. | Measuring module X (displacement) inductive..... | 21 |
| 5.4.15. | Measuring module X (displacement) incremental | 22 |
| 5.4.16. | Measuring module X (displacement) SSI..... | 23 |
| 5.4.17. | Digital module 2x16 inputs and outputs | 24 |

2. Note on safety



- Do not operate the device in areas with danger of explosion.
- An operation of the device in areas with risk of explosion is not permitted.



3. Description of the system

3.1. General function

The multi-channel force/displacement measuring system DMF-P A400 was especially designed for the use in units and systems with several joining processes, which are monitored independently from each other. Based on a two-channel device the system can be extended by connecting several devices according to the requirements. The network and data exchange both between the devices and with a possible external visualization is done per Ethernet.

The coupling to the unit can be carried out via Fieldbus or corresponding control inputs. In extreme cases each device can be operated autonomously. In the same way, the single channels are independent from each other.

The configuration / putting into operation is performed by a device with screen or a PC with web browser. It was emphasized on a clear and simple user prompting. Continuity with the previous devices of the DMF-P series was observed and many more functions have been added.

Features:

- ü Forward- backward measurement
- ü Traction-compression-applications
- ü Possibility of 4-quadrant measurement
- ü 32 setpoint records per channel
- ü 8 evaluation functions / window per setpoint record
- ü Graphically editable windows
- ü Additional window types: speed, under construction envelope curve, hysteresis, break point, gradient
- ü Online- and Offline-evaluations
- ü Statistic with protocol functions
- ü 100 curve memories per channel, 1000 measured value memories per channel (can be extended through memory expansion)
- ü Self-monitoring and diagnosis
- ü Open system for later extensions by modular construction
- ü Ethernet 10 / 100 MBit/s for networking
- ü Fieldbus-interfaces (optional)
- ü PS/2-Keyboard interface for easy handling
- ü Web server for visualization, modification and filing as well as remote control by a PC



3.2. Scope of delivery

Basic unit with a two-channel slide-in module each for X (displacement) and Y (force) and optional fieldbus interface and / or digital I/O-module.



3.3. Front view and description of positions

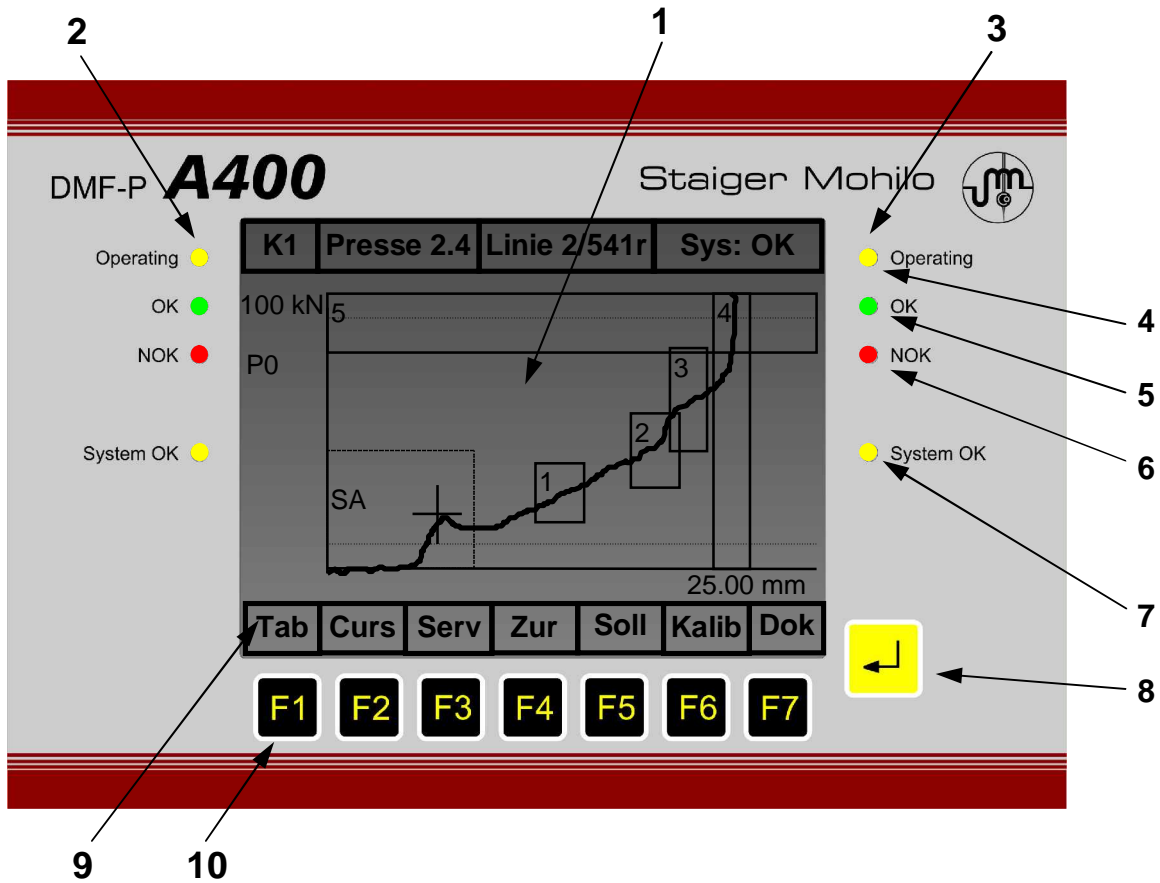

- 1 LC-screen with measuring curve and additional information
- 2 Signal lamps channel A
- 3 Signal lamps channel B
- 4 Signal lamp Operating, yellowMeasurement active
- 5 Signal lamp OK, green Measurement (joining) in tolerance range
- 6 Signal lamp NOK, red Measurement (joining) incorrect
- 7 Signal lamp system OK, yellow Device ready for operation
- 8 ENTER key, confirmation ENTER, accept the value
- 9 Description of the function keys e.g. key F1 à table
- 10 Function keys F1 to F7 menu-dependent functions

3.4. Rear view and description of positions

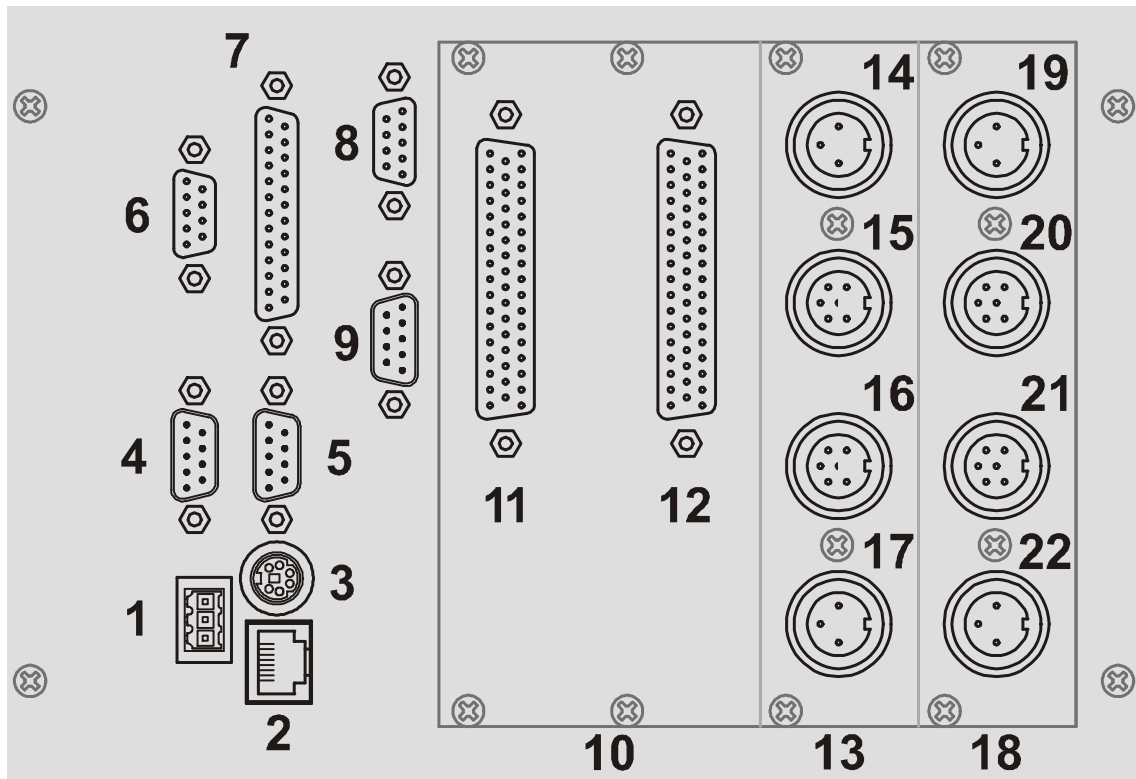

Basic unit, depending on the configuration and options

1. Supply (24 V DC)
2. LAN (Ethernet)
3. PS2-keyboard
4. serial interface (COM1)
5. serial interface (COM2)
6. Profibus (Option)
7. Parallel-printer
8. Feldbus (Option)
9. Feldbus (Option)

Slide-in modules, depending on the configuration and options

10. Slide-in digital-E/A
11. PLC-channel A
12. PLC-channel B
13. Slide-in module displacement sensors
14. Displacement monitor output channel A
15. Displacement input channel A
16. Displacement input channel B
17. Displacement monitor output channel B
18. Slide-in module force sensors
19. Force-monitor output channel A
20. Force- input channel A
21. Force-input channel B
22. Force monitor output channel B

Description of the pin assignment, see chapter 5.



4. Measurement

The DMF-P A400 measures on both channels independently. X- and Y- signals are measured and evaluated per each channel synchronously (measuring curve). The measurement can be started through an external signal or an internal requirement (X-value, waypoint or Y-value, force).

Using the evaluation windows specified by the operator the measuring curve is evaluated and a clear GOOD (OK) or BAD (NOK)- identification is obtained.

4.1. Standard sequence of measuring cycle

Measuring sequence for one channel

(Measuring cycle is ended by 20% displacement reverse)

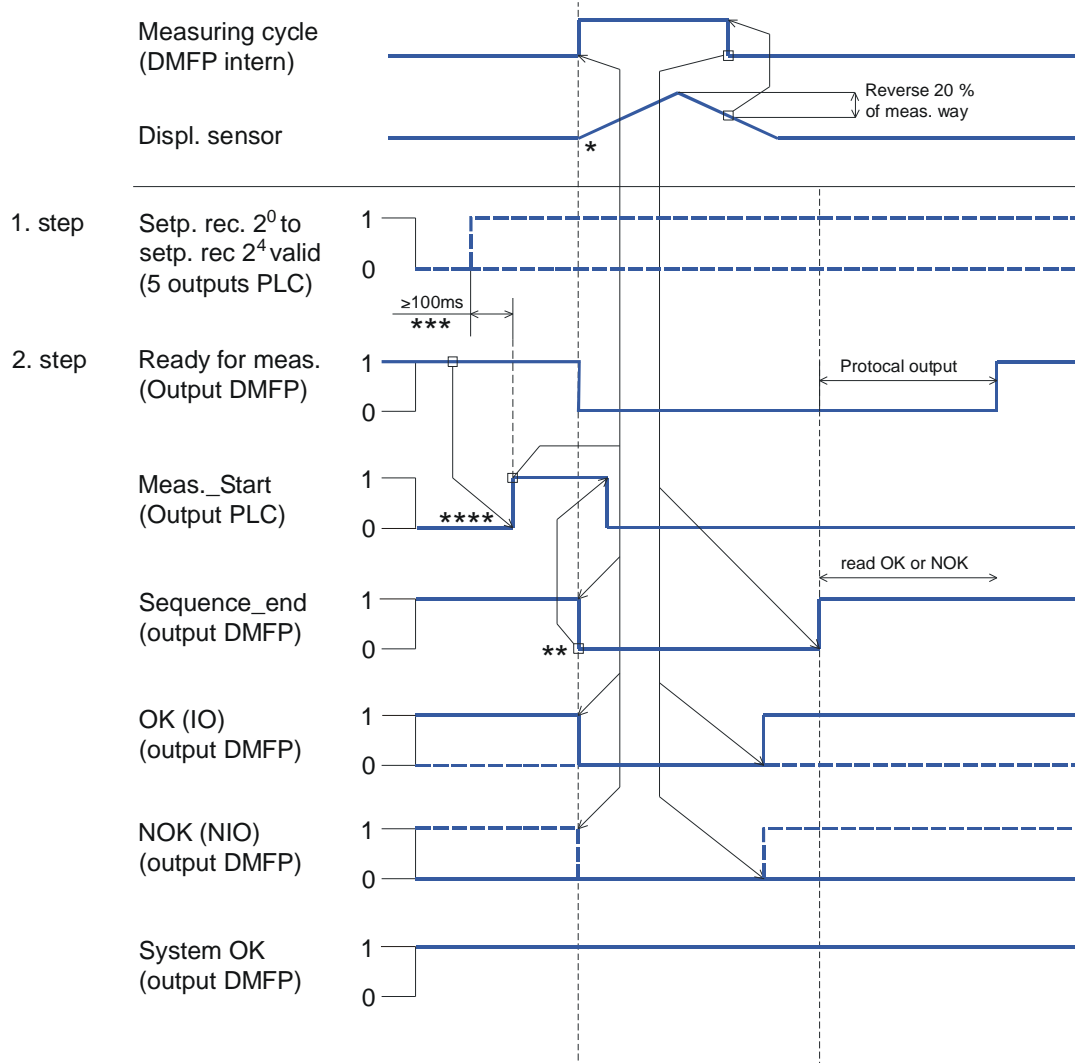

Caution: To end a started measuring cycle when a sequence is stopped (e.g. by emergency stop) apply "Measurement_Stop", until "Sequence_End" changes to stage 1 (high). (e.g. run to basic position or switching to manual operation)

- * Start of the force-fit movement only when "Sequence_End" is in stage 0 (low) !
- ** "Measurement_Start" can only be cut off if "Sequence_End" is in stage 0 (low) !
- *** 100 ms before "Measurement_Start" is activated, the PLC must set the outputs "Setp.rec⁰" to "Setp.rec⁴" for the required measuring program
- **** "Measurement_Start" is only accepted if the output "Ready" is in state 1 (high).

5. Activation and signals

5.1. Schematic diagram

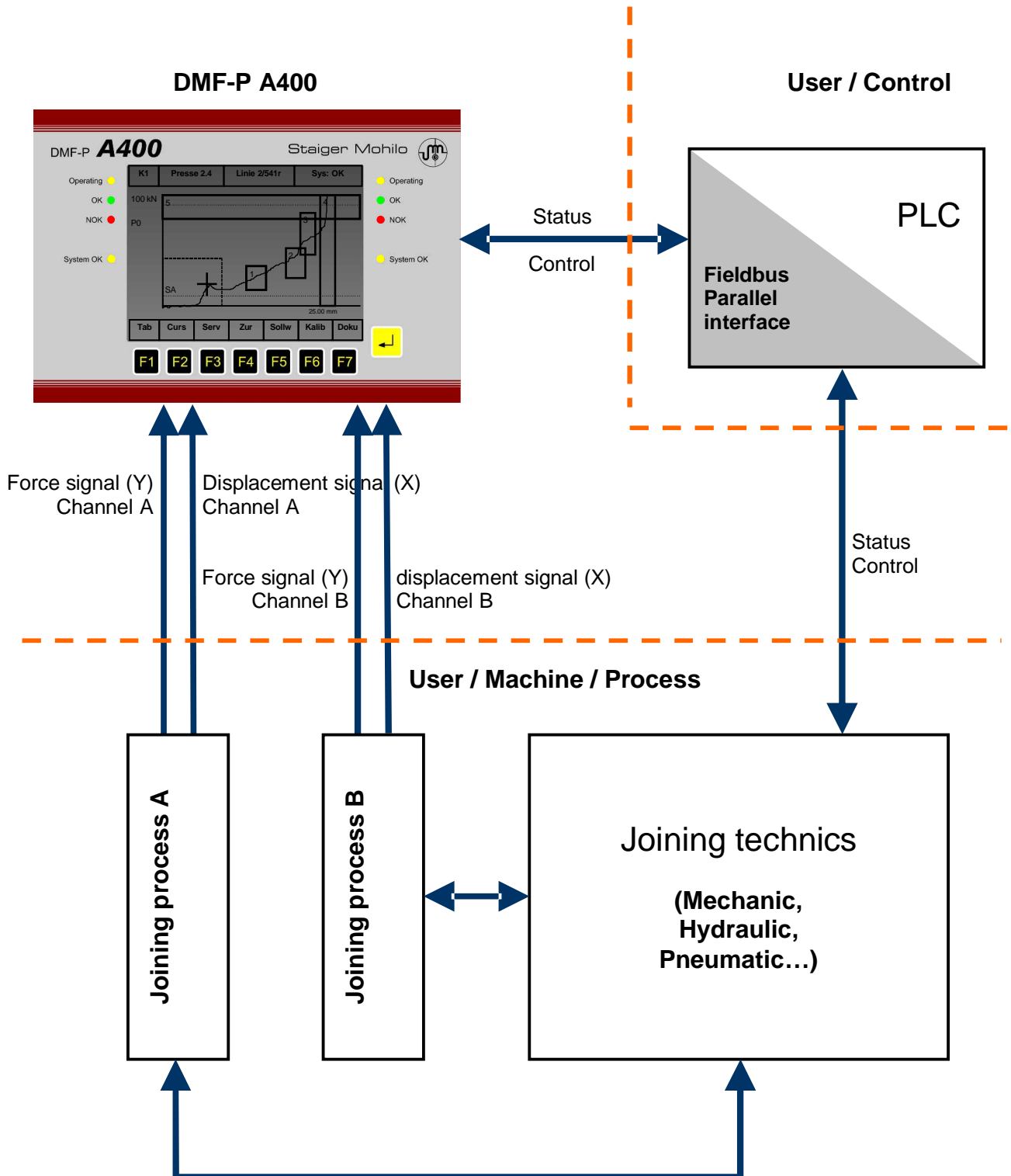



5.2. Parallel interface

Minimum pin assignment

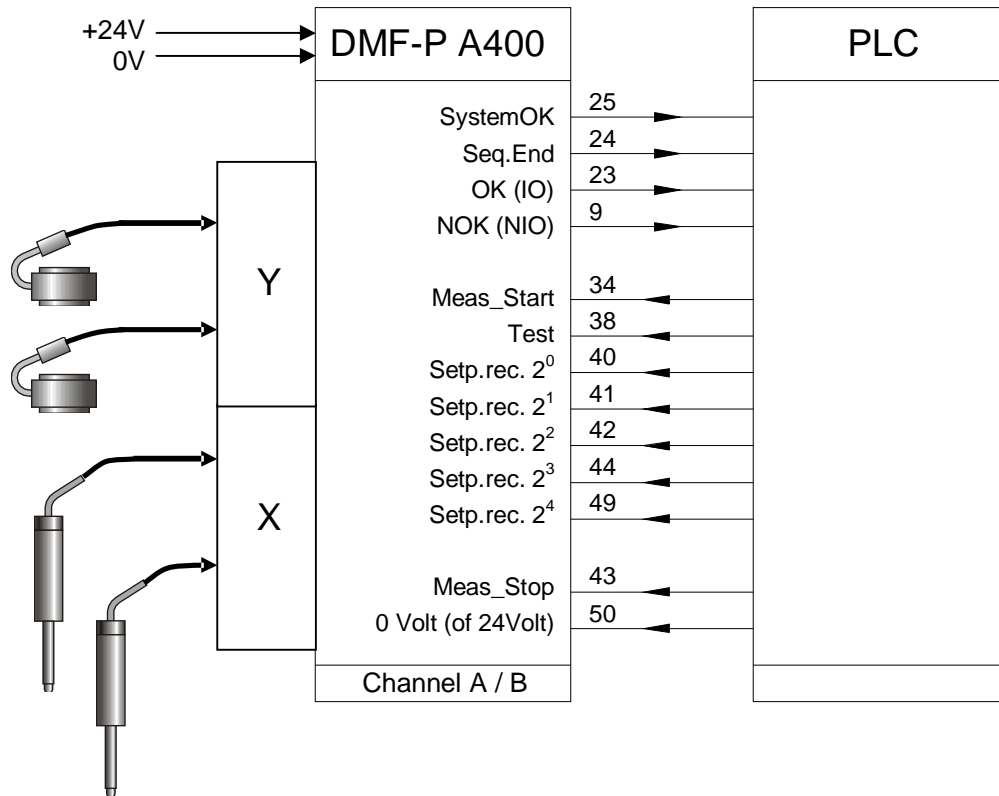

Connection - Example

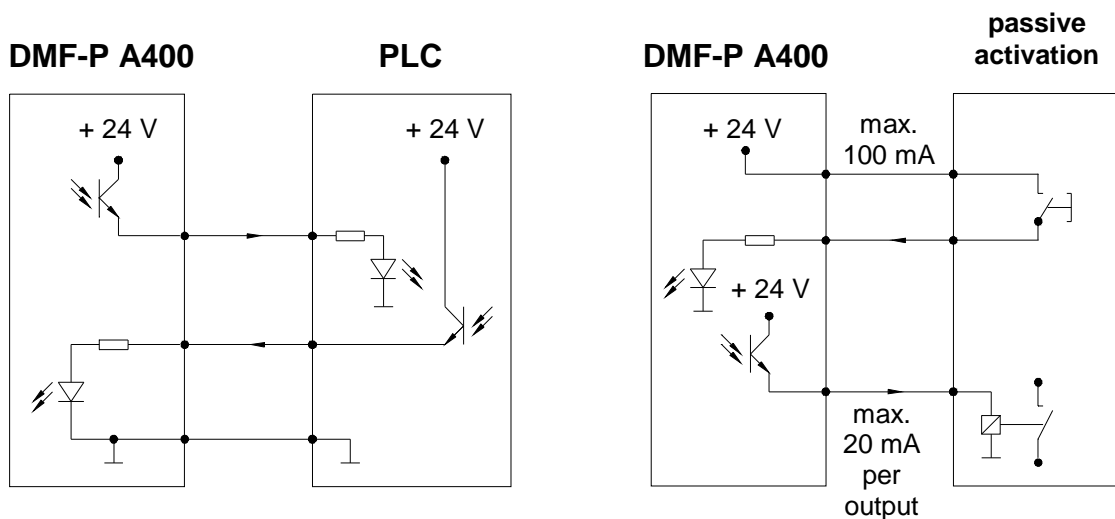

The total of all currents must not exceed 100 mA

5.3. Profibus

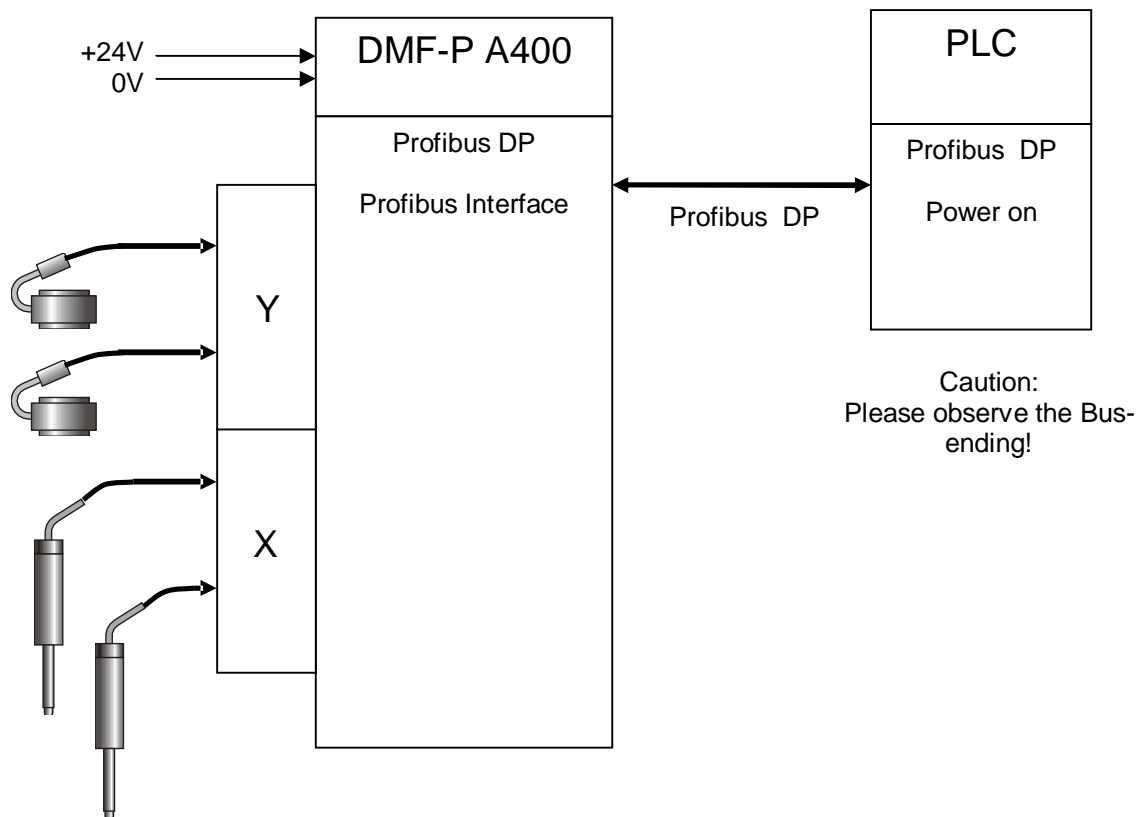



5.4. Interfaces

The basic unit provides the following interfaces:

Supply (24 V DC)

LAN (Ethernet)

Keyboard

Serial interface (COM1)

Serial interface (COM2)

Profibus (Option)

Parallel-printer

Fieldbus (Option)

Fieldbus (Option)

The connection of the measurement equipment is effected at the slide-in modules. Each slide-in module has for the channels A and B separate signal inputs and possibly outputs.

Depending on the device configuration the corresponding interfaces are available.

The following slide-in modules are available:

| Type | Item number |
|---|------------------------------|
| Measuring module Y (force) active 0..+/-10V | # 25100 |
| Measuring module Y (force) strain gage | # 25101 |
| Measuring module Y (force) Piezo | # 25102 |
| Measuring module X (displacement) active 0..+/-10V | # 25110 |
| Measuring module X (displacement) resistive | # 25111 |
| Measuring module X (displacement) inductive | # 25112 |
| Measuring module X (displacement) incremental | # 25113 (under construction) |
| Measuring module X (displacement) SSI | # 25114 (under construction) |
| Digital module 2x16 inputs and outputs | # 25120 |

5.4.1. Voltage supply

Connection: SL 3,5 / 3
 Designation: **24 V DC/30W**
 Counter-plug: BL 3,5 / 3 (Weidmüller)
 Assignment: + / 0V / PE

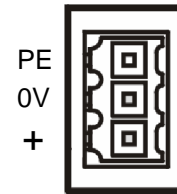

5.4.2. LAN (Ethernet)

Connection: 8-pol. RJ 45
 Designation: **LAN**
 Assignment:

| Pin | Signal |
|-----|--------|
| 1 | TX + |
| 2 | TX- |
| 3 | RX+ |
| 4 | n.b. |
| 5 | n.b. |
| 6 | RX- |
| 7 | n.b. |
| 8 | n.b. |

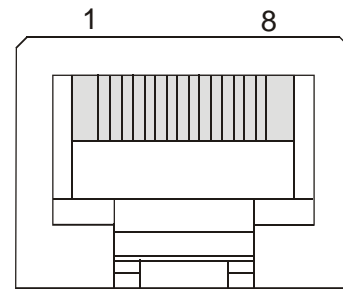

Address settings: see menu "**System menu**"

5.4.3. Keyboard

Connection: PS2 socket
 Designation: **Keyb.**
 Assignment:

| Pin | Signal |
|-----|--------|
| 1 | Data |
| 2 | n.b. |
| 3 | GND |
| 4 | +5V |
| 5 | CLK |
| 6 | n.b. |

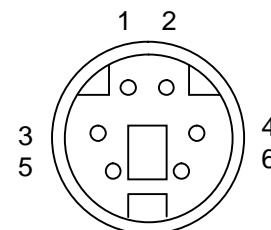



5.4.4. Serial interface RS-232 (COM1)

Protocol interface

Connection: D-Sub-plug, 9-pole

Designation: **COM1**

Assignment:

| Pin | Signal |
|-----|--------|
| 1 | DCD |
| 2 | RxD |
| 3 | TxD |
| 4 | DTR |
| 5 | GND |
| 6 | DSR |
| 7 | RTS |
| 8 | CTS |
| 9 | RI |

| Interface configuration | |
|-------------------------|------------|
| Baud | 9600 |
| Databit | 8 |
| Stopbit | 1 |
| Parity | none |
| Handshake | Xon / Xoff |

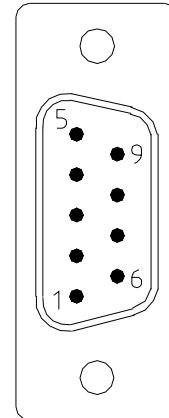

5.4.5. Serial interface RS-232 (COM2)

Reserve

Connection: D-Sub-plug, 9-pole

Designation: **COM2**

Assignment:

| Pin | Signal |
|-----|--------|
| 1 | DCD |
| 2 | RxD |
| 3 | TxD |
| 4 | DTR |
| 5 | GND |
| 6 | DSR |
| 7 | RTS |
| 8 | CTS |
| 9 | RI |

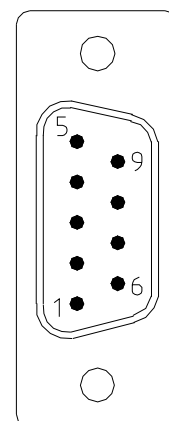

5.4.6. LPT (Printer interface parallel)

Connection: D-Sub-socket, 25-pole

Assignment: IBM-PC compatible (LPT)

This connection serves for data protocol with an HP-compatible printer.

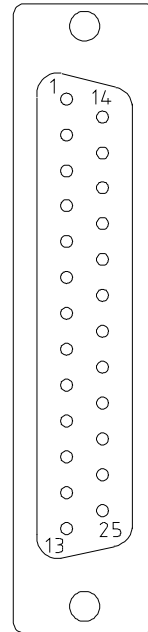

5.4.7. Profibus DP (Option)

Item number # 25090

Connection: D-Sub-socket, 9-pole

Assignment:

| Pin | Signal |
|---------|--------|
| 1 | --- |
| 2 | --- |
| 3 | B-Line |
| 4 | RTS |
| 5 | GND |
| 6 | Vcc |
| 7 | --- |
| 8 | A-Line |
| 9 | --- |
| Housing | shield |

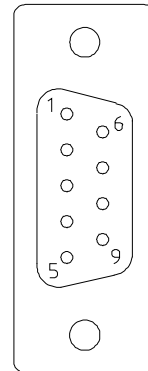

Baudrate: automatic recognition 9600 Bit/s – 12 MBit/s

Address-setting: see menu "System settings"

5.4.8. Fieldbus

Further Fieldbus adaptations are being prepared (Interbus S, Device-Net..)



5.4.9. Measuring module Y (force) active 0 ... ±10V

Item number # 25100

Measuring input

Connection: Round connector socket, 6-pole
(Standard sensor connection) per channel

Assignment:

| Pin | Signal |
|-----|-------------|
| 1 | supply - * |
| 2 | supply + * |
| 3 | Shield |
| 4 | meas. input |
| 5 | mass 0V |
| 6 | /Operate |

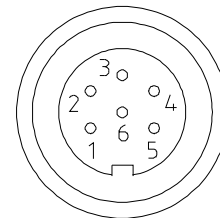

* Supply depending on the configuration

(Standard configuration +24V / 0V)

Monitor output

Connection: Round connector socket,
3-pole per channel

Assignment:

| Pin | Signal |
|-----|-------------------|
| 1 | output 0 ... ±10V |
| 2 | Shield |
| 3 | Mass 0V |

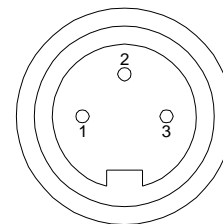

Output standardization 8V = 100%

Rear view

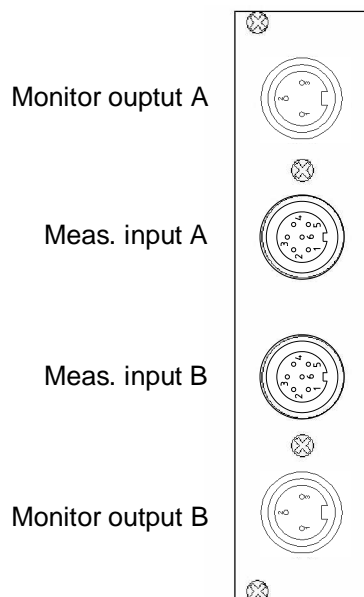

5.4.10. Measuring module Y (force) strain gage

Item number # 25101

Measuring input

Connection: Round connector socket, 6-pole
(Standard sensor connection) per channel

Assignment:

| Pin | Signal |
|-----|--------------------------|
| 1 | Strain gage supply - * |
| 2 | Strain gage supply + * |
| 3 | Shield |
| 4 | Strain gage meas. inp. + |
| 5 | Strain gage meas. inp. - |
| 6 | Calibration signal |

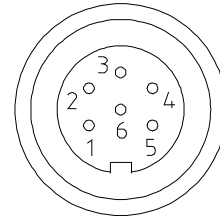

* Supply depending on the configuration

Monitor output

Connection: Round connector socket,
3-pole per channel

Assignment:

| Pin | Signal |
|-----|-------------------|
| 1 | Output 0 ... ±10V |
| 2 | Shield |
| 3 | Mass 0V |

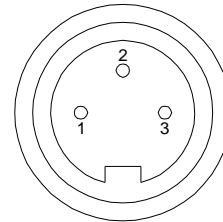

Output standardization 8V = 100%

Rear view

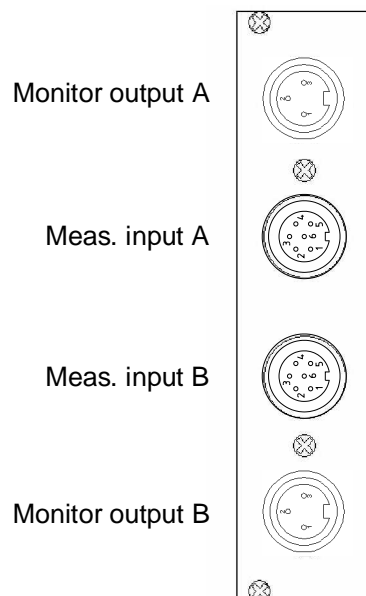



5.4.11. Measuring module Y (force) Piezo

Item number # 25102

Measuring input

Connection: BNC-socket per channel

Assignment:

| Pin | Signal |
|-----|------------------------|
| 1 | Meas. input |
| 2 | Mass (outer conductor) |

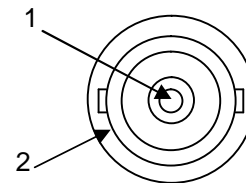

Monitor output

Connection: Round connector socket, 3-pole per channel

Assignment:

| Pin | Signal |
|-----|-------------------|
| 1 | Output 0 ... ±10V |
| 2 | Shield |
| 3 | Mass 0V |

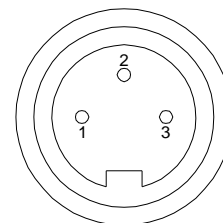

Output standardization 8V = 100%

Rear view

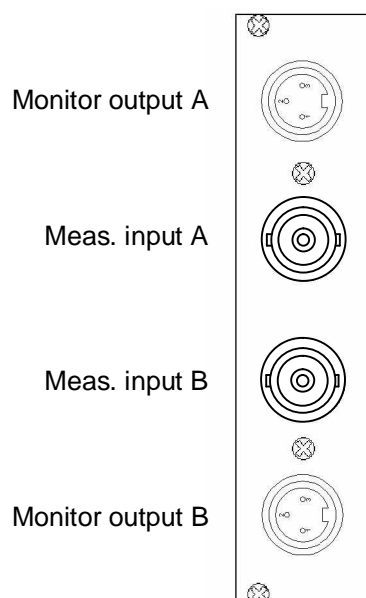

5.4.12. Measuring module X (displacement) active 0 ... ±10V

Item number # 25110

Measuring input

Connection: Round connector socket, 5-poles per channel

Assignment:

| Pin | Signal |
|-----|-------------------|
| 1 | Input Meas-Signal |
| 2 | Supply + * |
| 3 | Mass 0V |
| 4 | Shield |
| 5 | Supply - * |

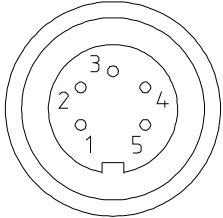

* Supply depending on the configuration

(Standard configuration +24V / 0V)

Monitor output

Connection: Round connector socket, 3-poles per channel

Assignment:

| Pin | Signal |
|-----|-------------------|
| 1 | Output 0 ... ±10V |
| 2 | Shield |
| 3 | Mass 0V |

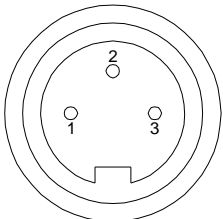

Output standardization 8V = 100%

Rear view

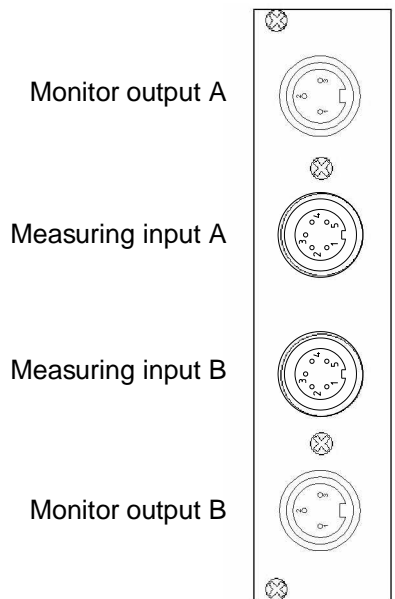



5.4.13. Measuring module X (displacement) resistive

Item number # 25111

Measuring input

Connection: Round connector socket, 5-poles per channel

Assignment:

| Pin | Signal |
|-----|-------------------|
| 1 | Input meas-signal |
| 2 | Supply 1 (10 V) |
| 3 | Supply 2 (0 V) |
| 4 | Shield |
| 5 | --- |

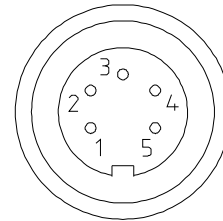

Monitor output

Connection: Round connector socket, 3-poles per channel

Assignment:

| Pin | Signal |
|-----|-------------------|
| 1 | Output 0 ... ±10V |
| 2 | Shield |
| 3 | Mass 0V |

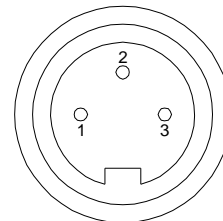

Output standardization 8V = 100%

Rear view

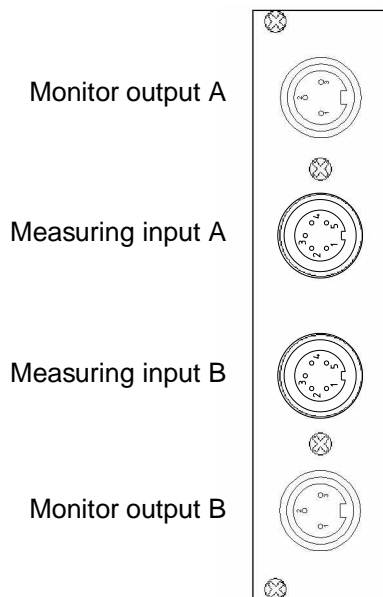



5.4.14. Measuring module X (displacement) inductive

Item number # 25112

Measuring input

Connection: Round connector socket, 5-poles per channel

Assignment:

| Pin | Signal |
|-----|-------------------|
| 1 | Input meas-signal |
| 2 | Supply 1 (10 V) |
| 3 | Supply 2 (0 V) |
| 4 | Shield |
| 5 | --- |

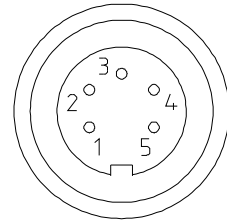

Monitor output

Connection: Round connector socket, 3-poles per channel

Assignment:

| Pin | Signal |
|-----|-------------------|
| 1 | Output 0 ... ±10V |
| 2 | Shield |
| 3 | Mass 0V |

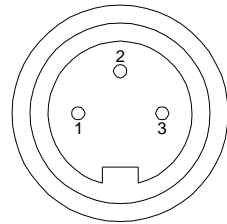

Output standardization 8V = 100%

Rear view

Monitor output A

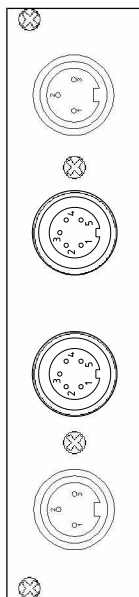

Measuring input A

Measuring input B

Monitor output B



5.4.15. Measuring module X (displacement) incremental

Item number # 25113

Measuring input

Connection: Round connector socket,
8-pole per channel

Belegung:

| Pin | Signal |
|-----|-----------------|
| 1 | pulse 1 + |
| 2 | pulse 1 - |
| 3 | pulse 2 + |
| 4 | pulse 2 - |
| 5 | Supply + 5 V |
| 6 | Supply 0 V |
| 7 | Shield |
| 8 | Reference point |

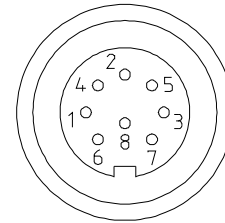

A monitor output is not provided

Rear view

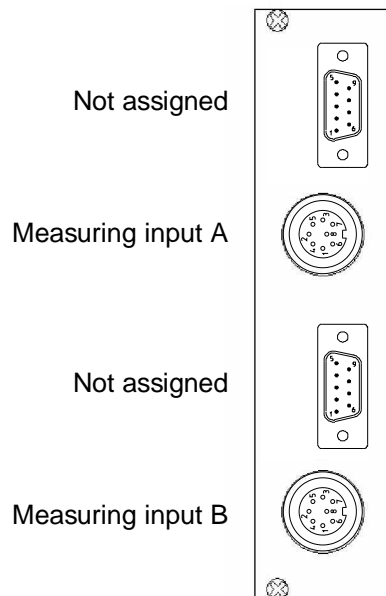

5.4.16. Measuring module X (displacement) SSI

Item number # 25114

Measuring input

Connection: D-Sub-plug,
9-pole (standard sensor connection)

Additional information to the SSI signal can be obtained from the instruction manual of the transmitter.

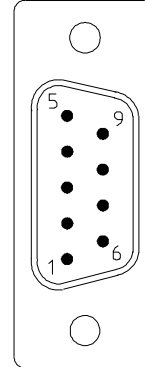

A monitor output is not provided.

Rear view

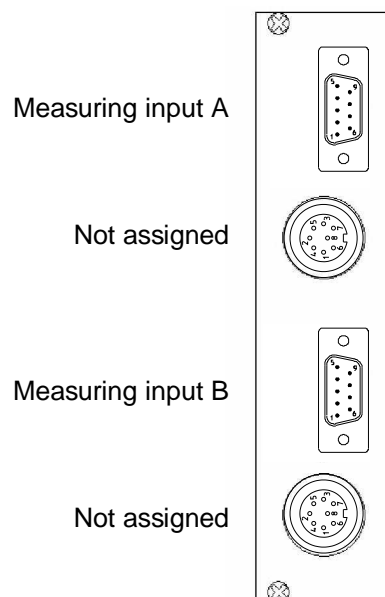



5.4.17. Digital module 2x16 inputs and outputs

Item number # 25120

Connection: D-Sub-socket, 50-pol per channel

| Pin | Digital In | Digital Out | | | |
|-----|----------------------------------|-------------|-----------------------|--------------------|---------------------|
| | | Pin | Measuring method 1/2 | Measuring method 3 | Measuring method 4 |
| 34 | Measurement start | 25 | SystemOK | SystemOK | SystemOK |
| 35 | X zero | 24 | Sequence end | Sequence end | Sequence end |
| 36 | Master measurement | 23 | OK (IO) | OK (IO) | OK (IO) |
| 37 | | 22 | max F1 | F1 | F1 |
| 38 | Test sequence | 21 | min F1 | F2 | F2 |
| 39 | In Position | 20 | max F2 | F3 | F3 |
| 40 | Program selection 2 ⁰ | 19 | min F2 | F4 | F4 |
| 41 | Program selection 2 ¹ | 18 | max F3 | F5 | F5 |
| 42 | Program selection 2 ² | 33 | min F3 | F6 | F6 |
| 43 | Measurement stop | 32 | max F4 | F7 | F7 |
| 44 | Program selection 2 ³ | 31 | min F4 | F8 | F8 |
| 45 | Y zero | 30 | | | |
| 46 | | 29 | | | |
| 47 | Key switch | 28 | | | |
| 48 | | 27 | | | |
| 49 | Program selection 2 ⁴ | 26 | | | |
| 50 | 0 V (reference) | 16 | | | |
| | | 15 | | | |
| | | 14 | | | |
| | | 13 | Y Trigger Start | | |
| | | 12 | Y Trigger End/SA | | |
| | | 11 | X Trigger End | | |
| | | 10 | Ready | | |
| | | 9 | NOK (NIO) | NOK (NIO) | NOK (NIO) |
| | | 17 | 0 Volt | 0 Volt | 0 Volt |
| | | 7 | Output voltage + 24 V | | Output, max. 100 mA |
| | | 8 | Output voltage + 24 V | | Output, max. 100 mA |

| | Voltage | Current |
|----------------|---------------|---------|
| Inputs | 24 V (± 10 %) | 10 mA |
| Outputs | 24 V (± 10 %) | 20 mA |

All the inputs and outputs are galvanically separated from the measuring electronics. The insulation strength between both potentials is 60 Volt.

Rear view

