

S.I. Instruments
256 South Rd. Hilton
South Australia 5033
Ph (08) 8352 5511

info@si-instruments.com
www.si-instruments.com

KISTLER
measure. analyze. innovate.



Instruction Manual

Mini-Smart Torque Sensor Type 4502A...

Version Q
(with standard square
connections)

Version H
(with standard hexagon
connections)

Version QA/HA
(with rotating angle
measuring system)

Version RA
(with round shaft and
rotation angle
measurement)

Foreword

We thank you for choosing a Kistler quality product distinguished by technical innovation, precision and long life.

Information in this document is subject to change without notice. Kistler reserves the right to change or improve its products and make changes in the content without obligation to notify any person or organization of such changes or improvements.

© 2008 Kistler Group. All rights reserved. Except as expressly provided herein, no part of this manual may be reproduced for any purpose without the express prior written consent of Kistler Group.

Kistler Group
Eulachstrasse 22
8408 Winterthur
Switzerland
Tel. +41 52 224 11 11
Fax +41 52 224 14 14
info@kistler.com
www.kistler.com

Content

1.	Introduction.....	3
2.	Important Information	4
2.1	Disposal Instructions for Electrical and Electronic Equipment.....	4
3.	Application and Key Features.....	5
4.	Description of the Measuring System.....	6
4.1	Mechanical Design.....	6
4.2	Electrical Block Diagram.....	7
4.2.1	Examples of Application	8
4.3	Rotation Angle Measuring System (Version QA/HA and RA only)	9
4.4	Adjustment for Angle-Pulse Output (Version QA/HA and RA only).....	10
5.	Electrical Connections.....	11
5.1	Plug Connection (Tuchel, 12 pin).....	12
5.1.1	Installing the Signal Lead.....	12
5.2	Instruction for Electrical Installation	13
5.3	Connecting Cable.....	14
5.3.1	Cable Diagram with Plugs on Both Sides	14
5.3.2	Cable Diagram, Plug (Sensor), Open Ends, Article-No.: 12497	14
6.	Mechanical Application	15
6.1	Versions Q, QA, H and HA.....	15
6.2	Torque Measuring Shaft Version RA.....	16
6.3	Possible Installation of Version RA.....	17
6.4	Supply Circuit and Evaluation.....	18
7.	Static Calibration.....	19
7.1	Construction of a Simple Calibration Device	19
7.2	Calculation Example for Lever Arm Length	20
8.	Maintenance	21
9.	Repairs.....	22

Total Pages 22

1. Introduction

Please take the time to thoroughly read this instruction manual. It will help you with the installation, maintenance, and use of this product.

Kistler offers a wide range of products for use in measuring technology:

- Piezoelectric sensors for measuring force, torque, strain, pressure, acceleration, shock, vibration and acoustic-emission
- Strain gage sensor systems for measuring force and moment
- Piezoresistive pressure sensors and transmitters
- Signal conditioners, indicators and calibrators
- Electronic control and monitoring systems as well as software for specific measurement applications
- Data transmission modules (telemetry)

Kistler also develops and produces measuring solutions for the application fields engines, vehicles, manufacturing, plastics and biomechanics sectors.

Our product and application brochures will provide you with an overview of our product range. Detailed data sheets are available for almost all products.

If you need additional help beyond what can be found either on-line or in this manual, please contact Kistler's extensive support organization.

2. Important Information

2.1 Disposal Instructions for Electrical and Electronic Equipment

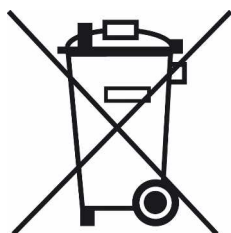

Do not discard old electronic instruments in municipal trash. For disposal at end of life, please return this product to an authorized local electronic waste disposal service or contact the nearest Kistler Instrument sales office for return instructions.

3. Application and Key Features

- Torque meter with strain gages measuring system
- Wear-resistant transmission of the measuring signal, integrated amplifier
- Measurement of constant and variable torques
- Torque measurement on the rotating shaft
- Integrated system for rotation angle measurement (only version QA/HA)
- Application in the laboratory, manufacture and quality control
- Ideal for use with power tools (version QA/HA) and test stand construction (version RA)
- Suitable for low and high speed ranges

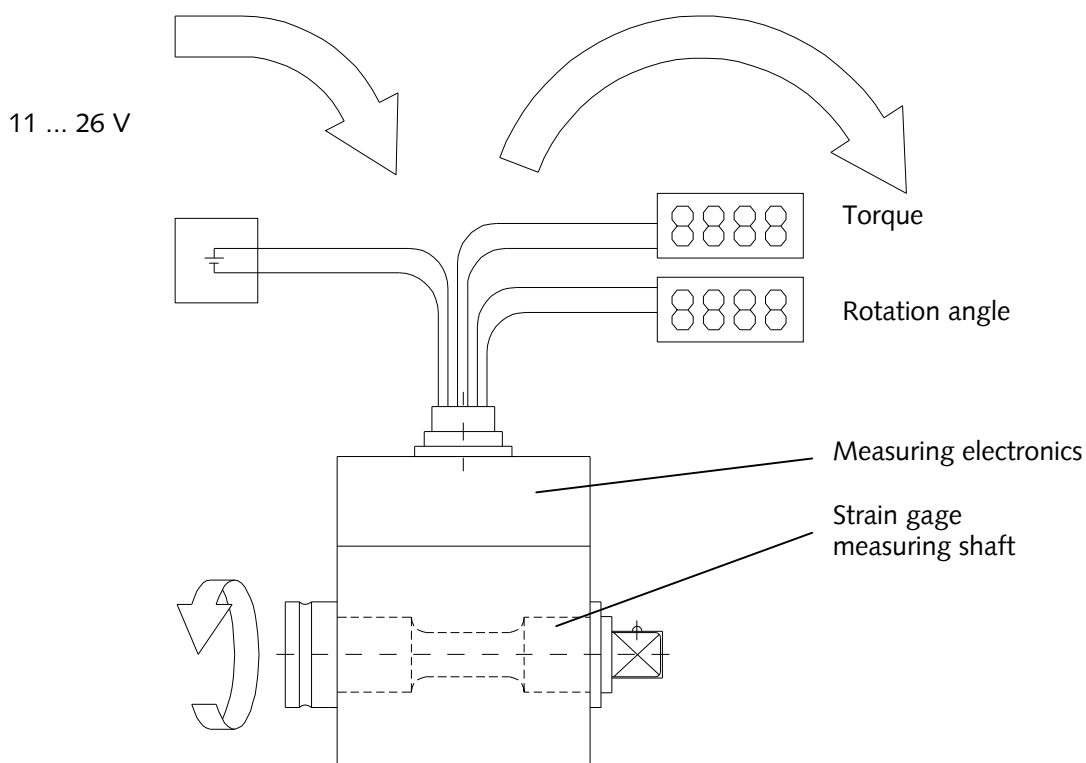

Fig. 1: Mini-Smart torque sensor

4. Description of the Measuring System

4.1 Mechanical Design

Torque Sensors type MS consist of a base body which contains the measuring shaft. The shaft ends are performed as standard square connections or standard hexagon ends.

On the measuring shaft there is a torsion distance with strain gauges and electronics with signal amplifier and A/D transformer.

The connection box of the base body contains the stationary electronics for the signal formation.

The base body of the Sensor offers different assembly possibilities (see chapter 5.2).

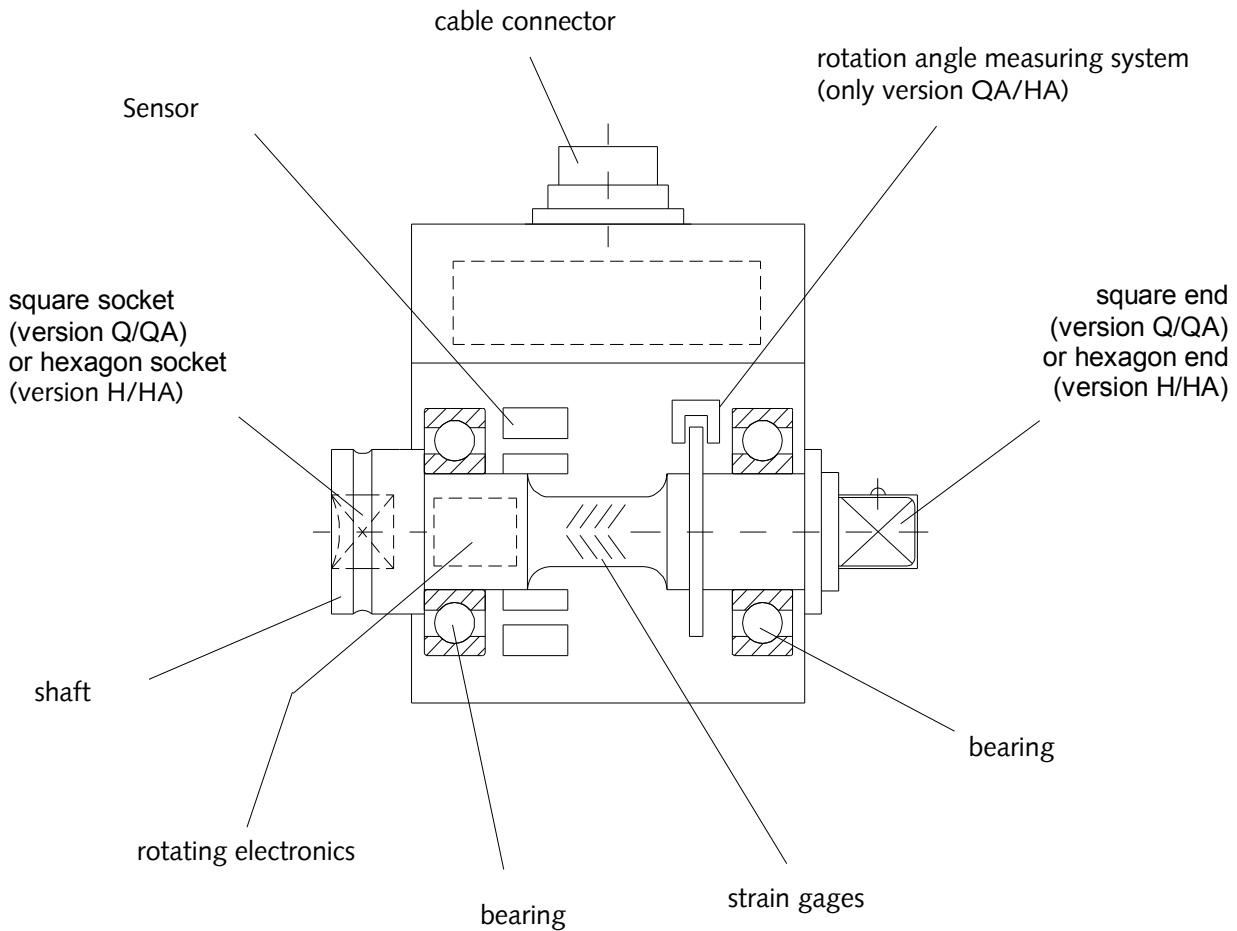

Fig. 2: Mechanical design Mini-Smart torque sensor Type 4502A...

4.2 Electrical Block Diagram

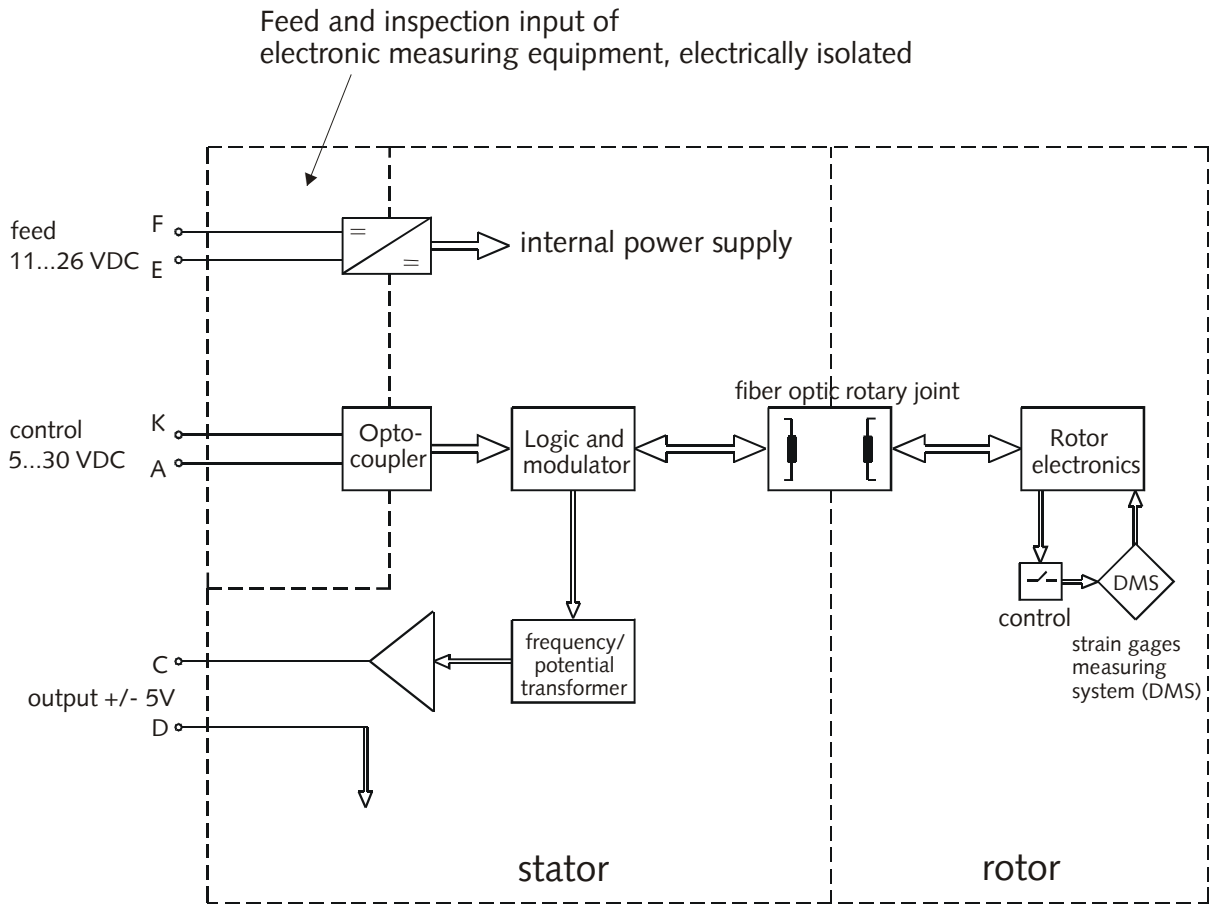
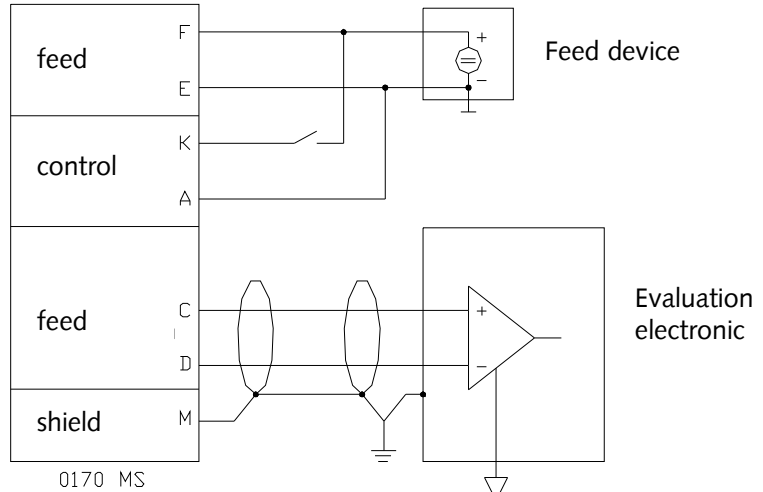

Fig. 3: Electrical block diagram

4.2.1 Examples of Application

Exactly use of electrical isolation for feed and measuring signal.



0170 MS
Fig. 4: Separate speed and measuring supply

Shared access measuring supply for feed and measuring supply.



Interlink the feed and measuring supply, evaluation electronic is to be made.

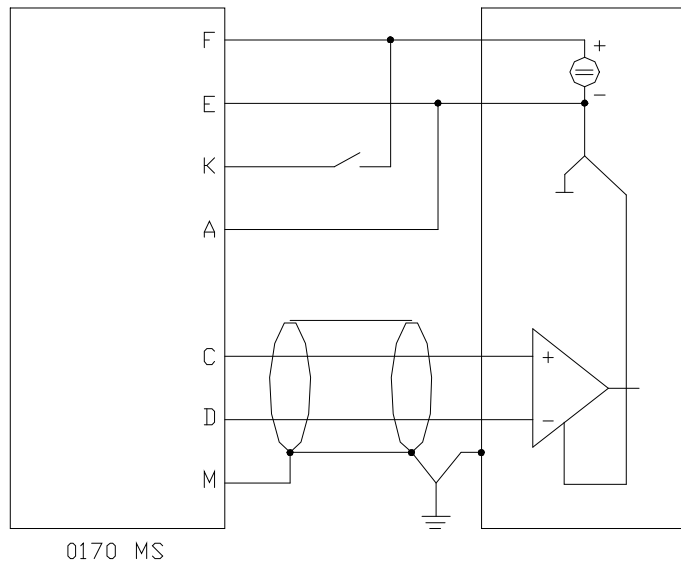

0170 MS
Fig. 5: feed and measuring supply in the evaluation electronic combined

4.3 Rotation Angle Measuring System (Version QA/HA and RA only)

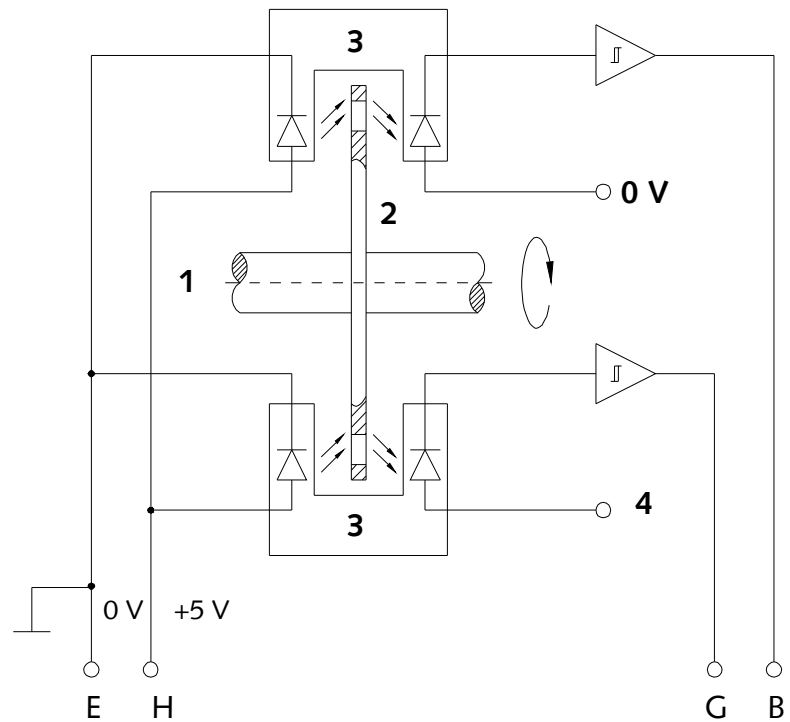

Fig. 6: Diagram showing the design of the rotation angle measuring system

1. Rotating shaft
2. Pulse disk
3. Forked light barrier with LED and photo diode
4. operation amplifier

Features:

- 360 light-dark stripes on the pulse disk
- Two forked light barriers shifted by phase angle 90°
- Pulse number proportional to the rotation angle

4.4 Adjustment for Angle-Pulse Output (Version QA/HA and RA only)

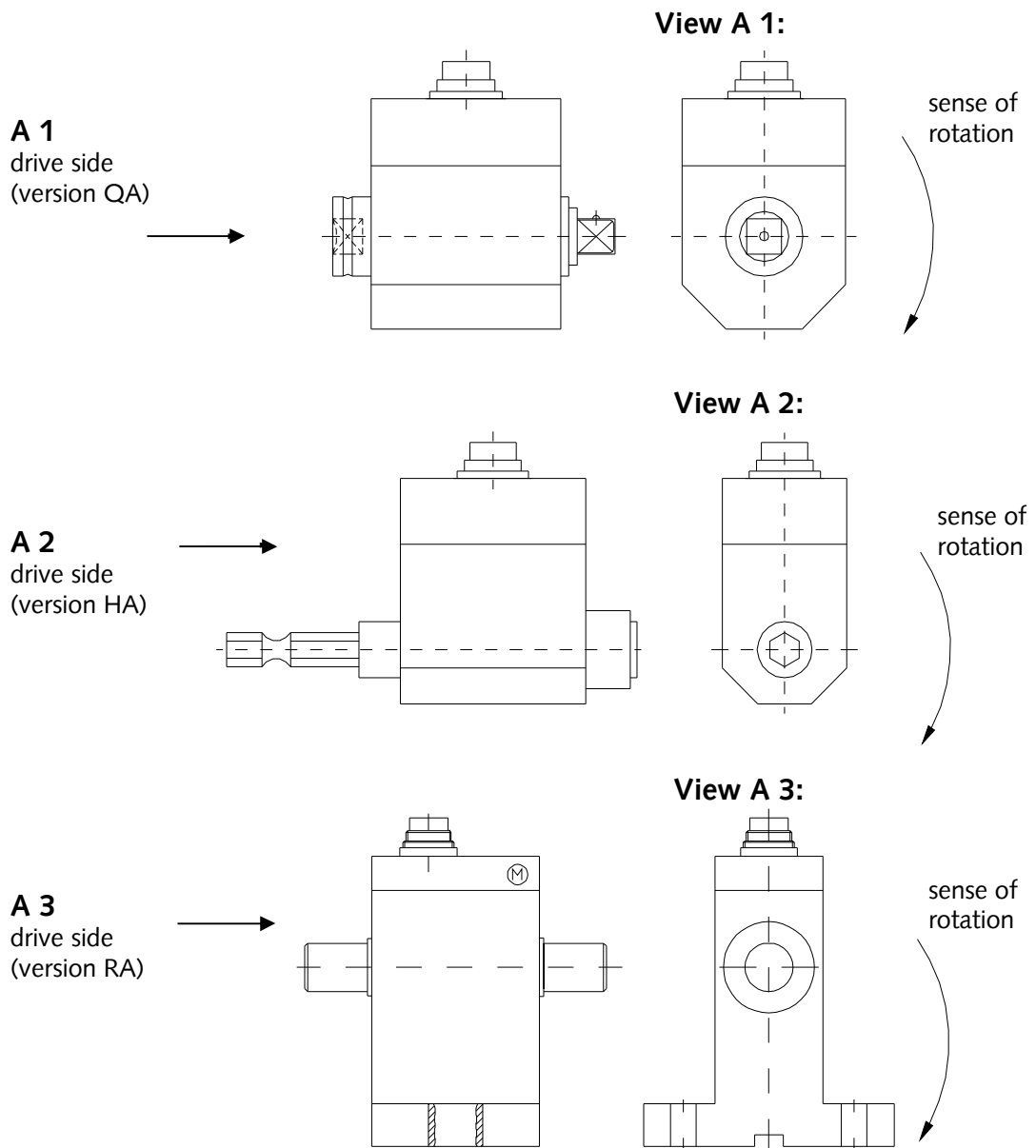
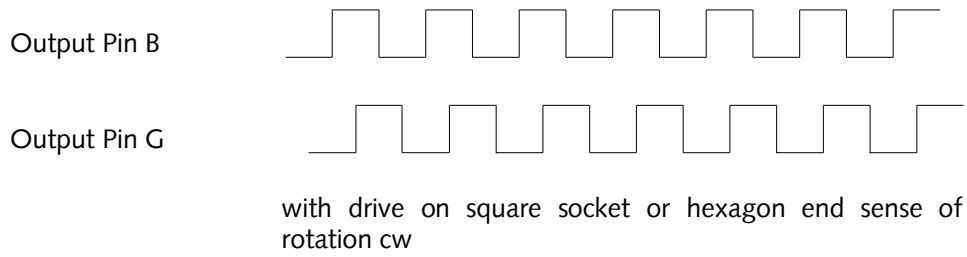

Fig. 7: Adjustment for angle-pulse output

5. Electrical Connections

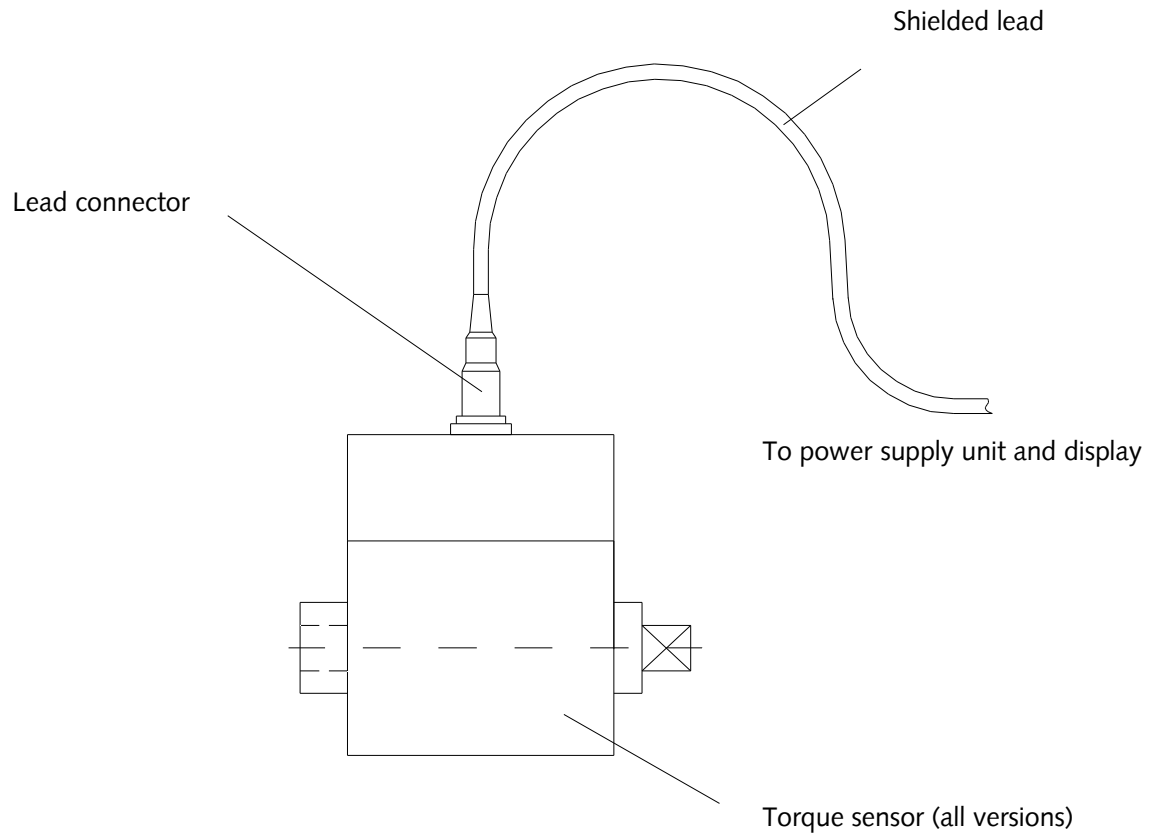

Fig. 8: Electrical connections

- Shielded lead of 0,14 mm² nominal cross section

5.1 Plug Connection (Tuchel, 12 pin)

Function	Pin
GND electric calibration input signal	A
Angle 1, speed	B
Measuring signal U_a ±5 VDC	C
GND measuring signal U_a ±5 VDC	D
GND supply voltage U_b , angle, speed	E
Supply voltage U_b +11 V ... +26 V, 1 W	F
Angle 2 (90° shifted to angle 1)	G
Supply angle +5 V	H
Torque range detection	J
El. Calibration input Kal. +5 V ... 30 VDC (activation generates a rated output voltage of +5 VDC)	K
GND torque range detection	L, option
Shield	M

Top view built-in plug

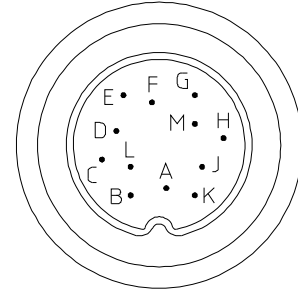

5.1.1 Installing the Signal Lead

- Do not run the lead parallel to power cables or control circuits.
- Do not place the lead close to equipment producing strong electromagnetic fields, e.g. transformers, welders, contactors, electric motors, etc.
- If such situations cannot be avoided, run the lead inside earthed steel conduit.
- Make a loop in the lead when fixing it at the torque meter so that it is not damaged by vibration. If supply and evaluation unit are galvanically connected, a differential input must be used for the torque signal to prevent that the voltage drop on the 0 V-supply line affects the measured signal

5.2 Instruction for Electrical Installation

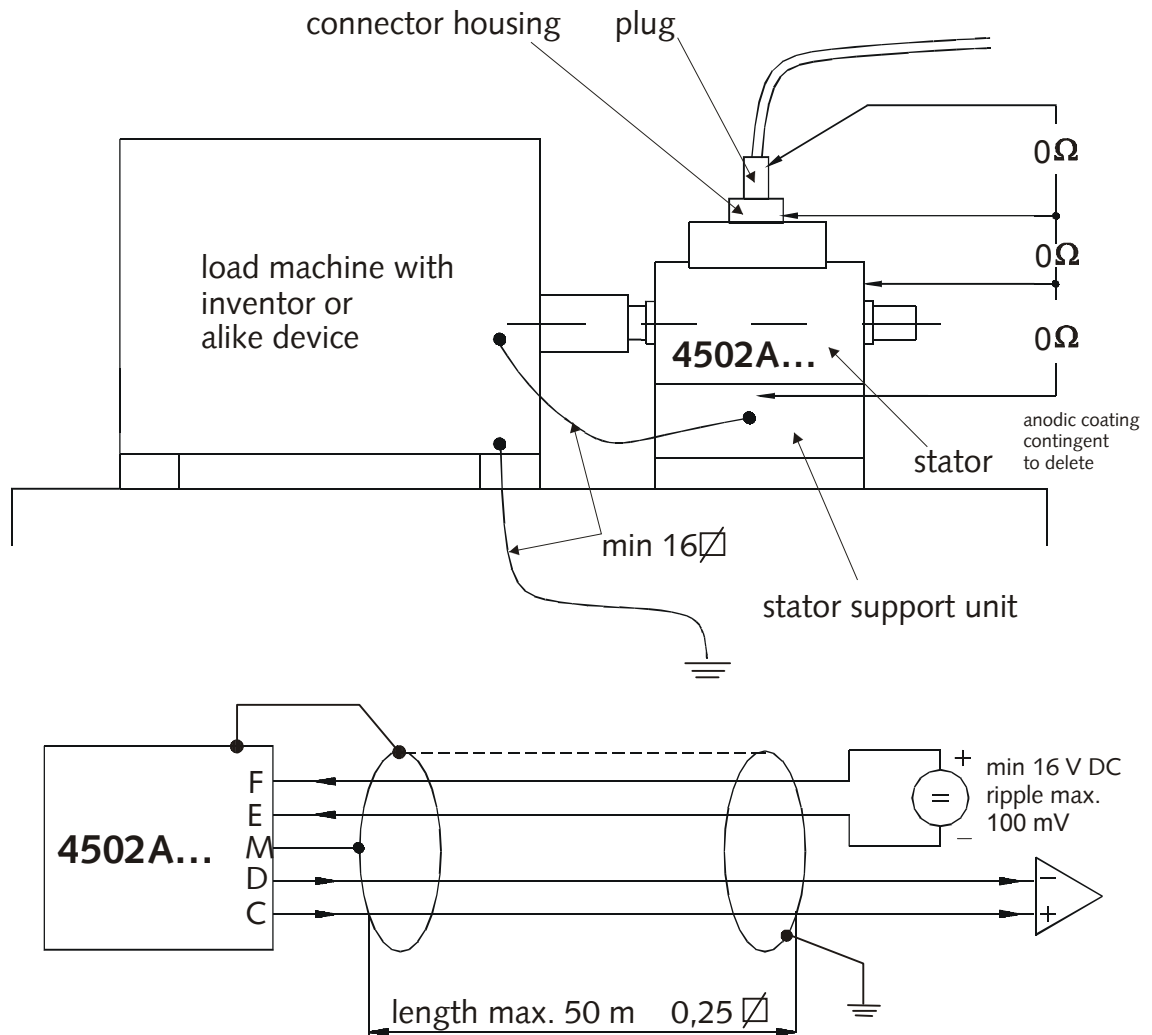

Fig. 9: Electrical installation

5.3 Connecting Cable

5.3.1 Cable Diagram with Plugs on Both Sides

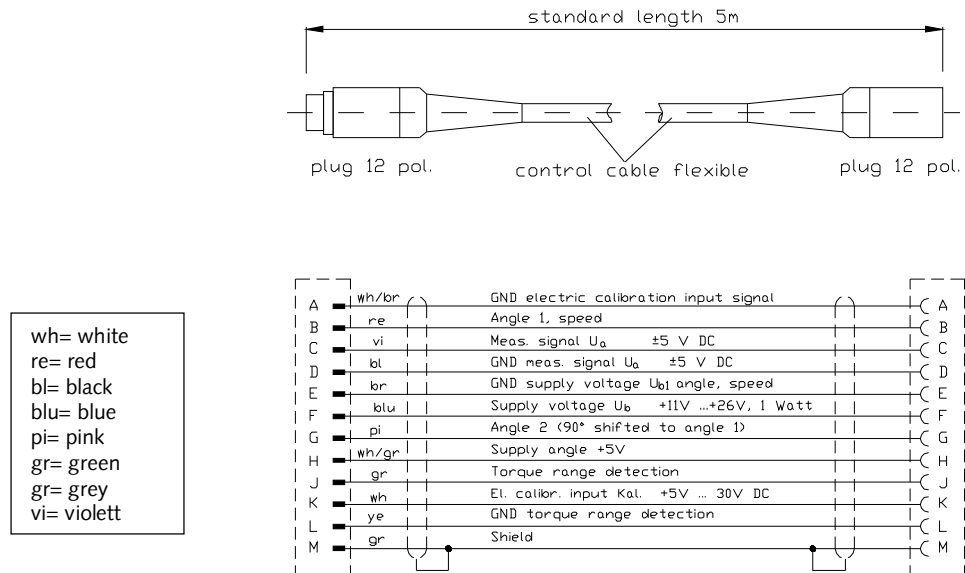

Fig. 10: Cable diagram with plugs on both sides

5.3.2 Cable Diagram, Plug (Sensor), Open Ends, Article-No.: 12497

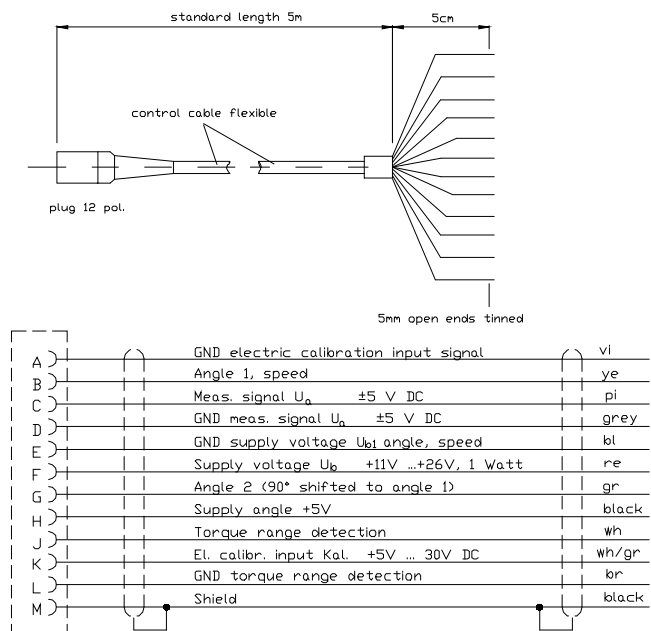

Fig. 11: Cable diagram, plug (sensor), open ends

6. Mechanical Application

6.1 Versions Q, QA, H and HA

- Torque meters of version Q and QA have square connections for plug-in tools acc. to DIN 3121
- Torque meters of version H and HA have hexagon connections acc. to DIN 3126, form E/F
- The torque meters are plugged on to the drive spindle as shown below

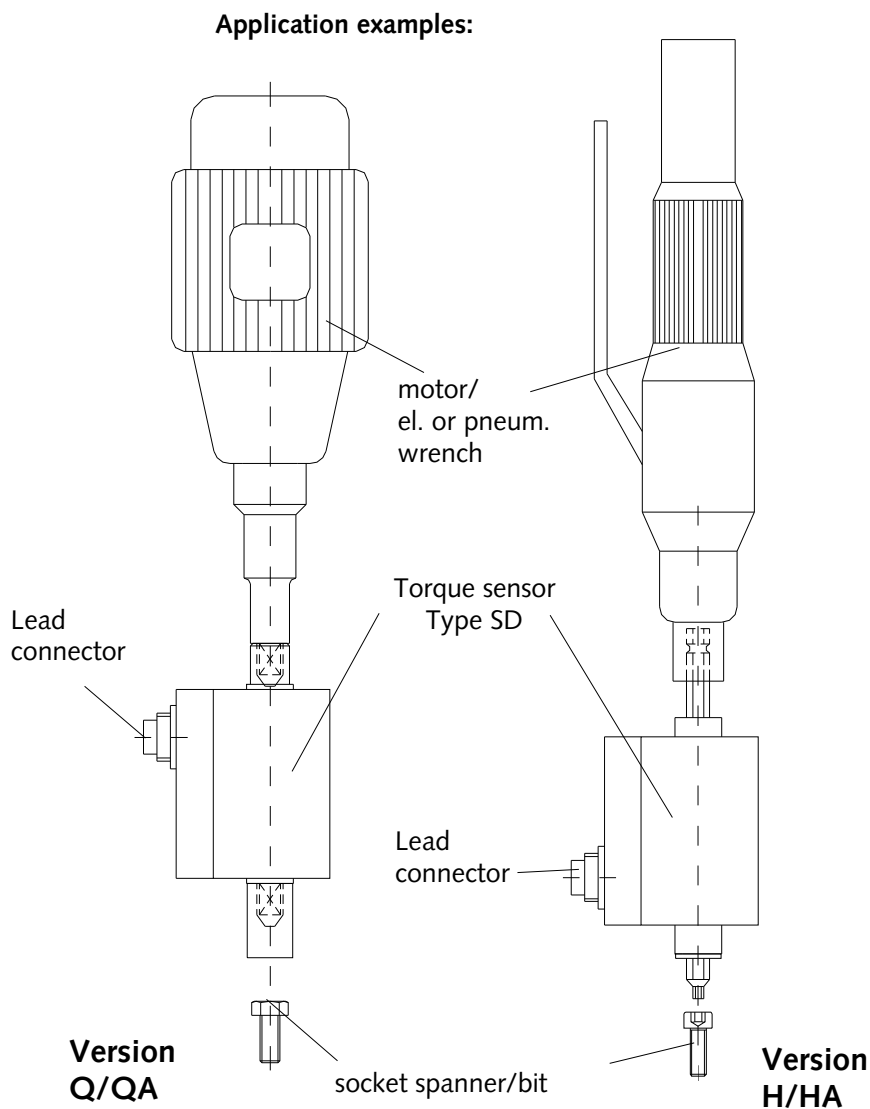

Fig. 12: Application examples versions Q/QA & H/HA

6.2 Torque Measuring Shaft Version RA

For the electric connection of measuring shaft and supply- and evaluation unit we recommend to use the shielded signal lead, art. no. 7203 with low capacity. Version VA 3600 is recommended as supply and evaluation unit.

The signal lead should not exceed a length of 30 meters. Do not run the lead parallel to power cables or control circuits.

The pin connection is explained in chapter 4.1 of this manual.

On each side of the torque measuring shaft there is a high quality bearing installed, and it contains an integrated housing base. The installation can have any position, however offset couplings must always be applied to balance geometrical false adjustments and like that keep false loads away from the torque measuring shaft.

Radial, axial, diagonal and angular errors are compensated by:

- Multi-disk couplings, e.g. data sheet 8301
- or diaphragma coupling
- or claw couplings

6.3 Possible Installation of Version RA

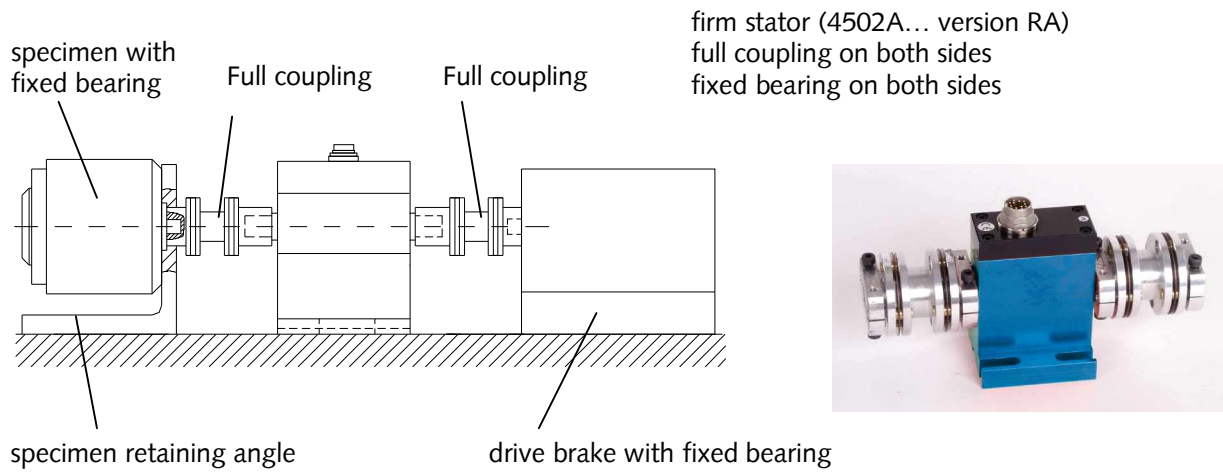

Fig. 13: Application example version R

Couplings compensate axial-radial and angular misalignment.

The connection of shaft and coupling hub is effected by a span device.

The measuring shaft is fastened with balancing class 6,5. The torque measuring shaft is only a part of the shaft strand.

Radial and torsional vibrations may have a very bad impact on the performance of the torque shaft and the measuring signal.

For that reason the operating speed must not be near the critical speed, either it has to be far underneath or above it.

6.4 Supply Circuit and Evaluation

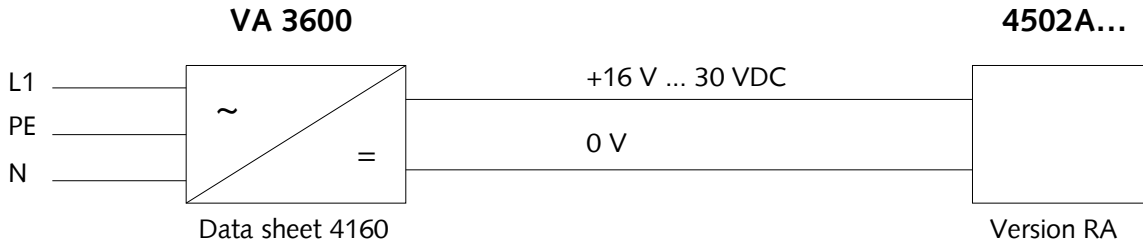

Terminal box for 4502A... version RA

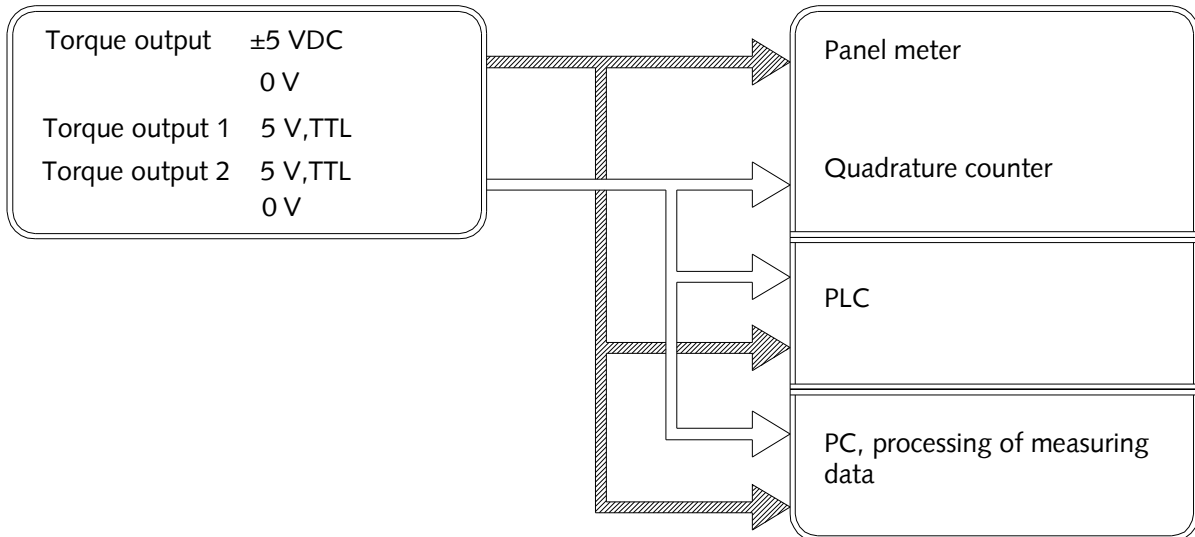

Fig. 14: Supply circuit and evaluation

7. Static Calibration

This procedure requires the use of a calibration device with a lever arm and weights for producing specific values of torque.

The calibration procedure is as follows:

- Apply the rated value of torque to the torque meter and then remove it again
- Adjust the zero reading accurately
- Apply a known value of torque to the torque meter
- Adjust the displayed reading to the corresponding value

Plotting a calibration curve

- Calibrate the torque meter as described above
- Apply torque in 1/10 steps up to the full rated value and then remove it again in the same way. A delay of at least 30 seconds must be allowed between the individual 1/10 steps so that each reading can stabilize before it is recorded

7.1 Construction of a Simple Calibration Device

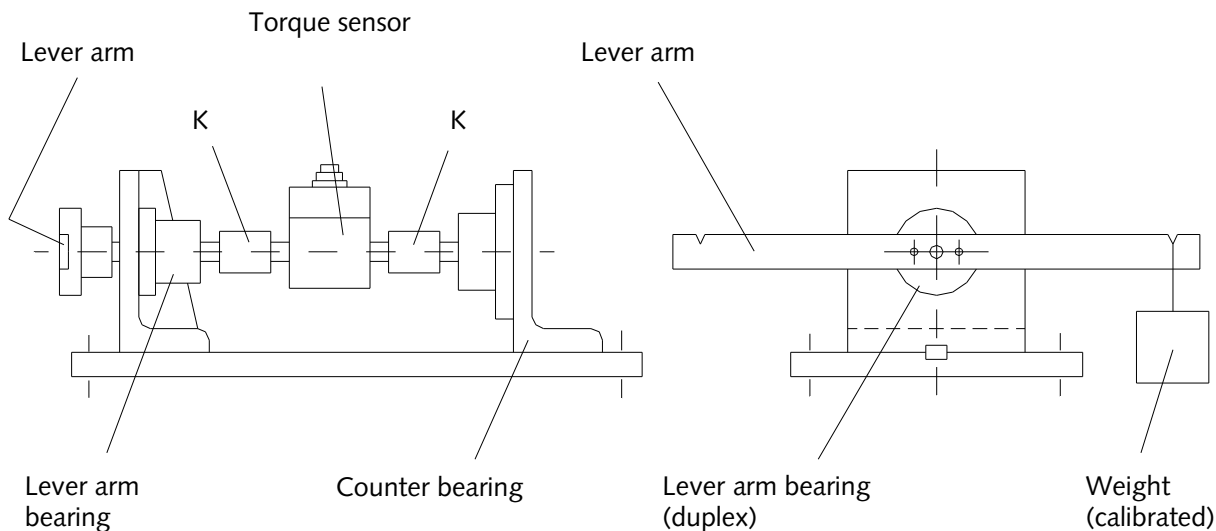

K = Loose half-couplings

Fig. 15: Calibration device

7.2 Calculation Example for Lever Arm Length

$$L = \frac{M}{m \cdot g}, \text{ whereby}$$

- M = Torque
- L = Length of lever arm required
- m = Mass required
- g = 9.80665 m/s²
(= standard gravity – varies with location)

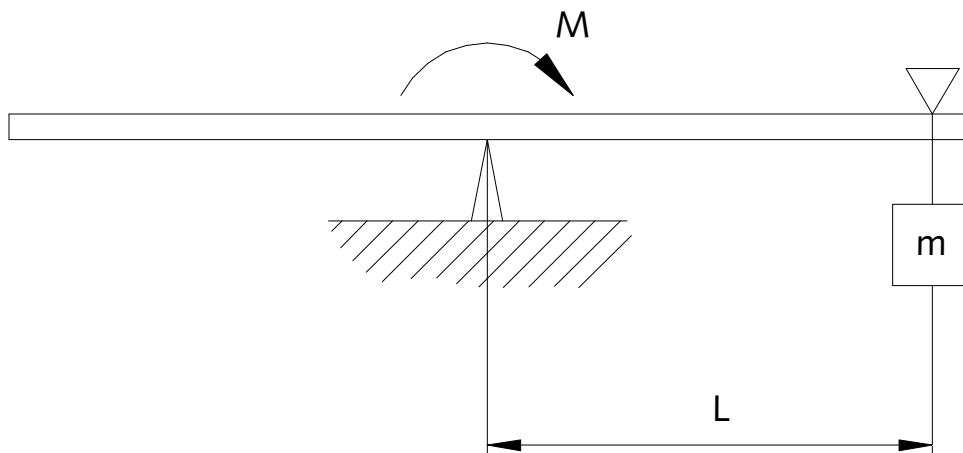

Fig. 14: Calculation of lever arm length

Example: m = 1 kg
M = 10 N·m

$$\rightarrow L = \frac{10 \text{ N}\cdot\text{m}}{1 \text{ kg} \times 9,80665 \text{ m/s}^2} = 1,0197 \text{ m}$$

8. Maintenance

- Sensors of the MS series are almost maintenance-free
- Durability of bearings in rated temperature range is approx. 20 000 hours
- Durability of bearings in working temperature range is approx. 10 000 hours
- Renewal of bearings can only be effected at works
- Precision applications: Yearly calibration of Sensor (calibration at works or with adequate calibration device)
- Control correct cable plug position monthly
- Check cables for damages monthly

9. Repairs

Fault	Cause	Remedy
Shaft stiff to turn	Bearing defect due to: a) Torsional or flexural vibration b) High axial or radial loads c) Worn bearings d) Bent shaft	Return to factory
Zero shift less than 2%	Torsional vibration Torsional shock	The zero reading can be readjusted at the display
Zero shift between approx. 2 and 5% of full scale	Torque meter has been overloaded Torsional vibration Torsional shock	The zero reading can be readjusted once at the display
Hysteresis between clockwise and anticlockwise torque	Torque meter overloaded by high alternating loads or torsional vibration	Return to factory
Shaft stiff to turn	Bearing defect due to: a) Torsional or flexural vibration b) High axial or radial loads c) Worn bearings d) Bent shaft	Return to factory
Zero shift less than 2%	Torsional vibration Torsional shock	The zero reading can be readjusted at the display