

S.I. Instruments
256 South Rd. Hilton
South Australia 5033
Ph (08) 8352 5511

info@si-instruments.com
www.si-instruments.com

KISTLER
measure. analyze. innovate.



Instruction Manual

Rotating Torque Sensor Type 4501A...

Version Q/QA
(with standard square
connections)

Version R
(with shaft ends)

Version H/HA
(with standard hexagon
connections)

Foreword

We thank you for choosing a Kistler quality product distinguished by technical innovation, precision and long life.

Information in this document is subject to change without notice. Kistler reserves the right to change or improve its products and make changes in the content without obligation to notify any person or organization of such changes or improvements.

© 2008 Kistler Group. All rights reserved. Except as expressly provided herein, no part of this manual may be reproduced for any purpose without the express prior written consent of Kistler Group.

Kistler Group
Eulachstrasse 22
8408 Winterthur
Switzerland
Tel. +41 52 224 11 11
Fax +41 52 224 14 14
info@kistler.com
www.kistler.com

Content

1.	Introduction.....	3
2.	Important Information	4
2.1	Disposal Instructions for Electrical and Electronic Equipment.....	4
3.	Application and Key Features.....	5
4.	Description.....	6
4.1	Mechanical Design	6
4.2	Electrical Design	7
4.3	Rotation Angle Measuring System (Version QA and HA only)	8
5.	Electrical Connections.....	10
5.1	Description of Interfaces.....	11
5.1.1	Versions Q/R/H:.....	11
5.1.2	Connection Cable Q/R/H.....	11
5.1.2.1	Cable Diagram with Plugs on Both Sides Article-No.: 7186, Versions Q/R/H	11
5.1.2.2	Cable Diagram, Plug (Transducer), Open Ends Article-No.: 10382, Versions Q/R/H	12
5.1.3	Versions QA/HA.....	13
5.1.4	Connection Cables QA.....	13
5.1.4.1	Cable Diagram with Plugs on Both Sides, Article-No.: 17069, Version QA.....	13
5.1.4.2	Cable Diagram, Plug (Transducer), Open Ends, Article-No.: 18315, Version QA.....	14
5.1.5	Version H (Special).....	15
5.1.6	Cable Diagram, Plug, Open Ends Article-No.: 7331, Version H (Special).....	15
5.2	Installing the Signal Lead	16
6.	Using the Torque Meter.....	17
6.1	Versions Q, QA, H, HA	17
6.2	Version R.....	18
7.	Static Calibration.....	19
7.1	Making a Simple Calibration Device	19
7.2	Calculation Example for Lever Arm Length	20
8.	Maintenance	21
9.	Repairs.....	22

Total Pages 22

1. Introduction

Please take the time to thoroughly read this instruction manual. It will help you with the installation, maintenance, and use of this product.

Kistler offers a wide range of products for use in measuring technology:

- Piezoelectric sensors for measuring force, torque, strain, pressure, acceleration, shock, vibration and acoustic-emission
- Strain gage sensor systems for measuring force and moment
- Piezoresistive pressure sensors and transmitters
- Signal conditioners, indicators and calibrators
- Electronic control and monitoring systems as well as software for specific measurement applications
- Data transmission modules (telemetry)

Kistler also develops and produces measuring solutions for the application fields engines, vehicles, manufacturing, plastics and biomechanics sectors.

Our product and application brochures will provide you with an overview of our product range. Detailed data sheets are available for almost all products.

If you need additional help beyond what can be found either on-line or in this manual, please contact Kistler's extensive support organization.

2. Important Information

2.1 Disposal Instructions for Electrical and Electronic Equipment

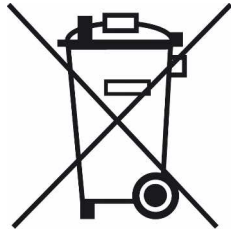

Do not discard old electronic instruments in municipal trash. For disposal at end of life, please return this product to an authorized local electronic waste disposal service or contact the nearest Kistler Instrument sales office for return instructions.

3. Application and Key Features

- Torque meter with strain gages
- Signal transfer by slip rings
- Measurement of constant and variable torque
- Measurement of torque from the rotating shaft
- Integrated system for rotation angle measurement (only version QA)
- Suitable for laboratory use and quality control
- Ideal for use with power tools
- Primarily suitable for low speed ranges
- Suitable for momentary measurement of torque (intermittent duty)

4. Description

4.1 Mechanical Design

Torque meters model SD comprise a rotating shaft mounted on bearings inside a housing. The shaft has a necked section - called the torsion zone - to which strain gages are attached and connected in a full bridge circuit. Slip rings and brushes provide the link between rotor and housing with two slip rings carrying the electric power supply to the strain gages on the rotating shaft. Two other slip rings serve to transfer the measuring signals from the rotating shaft to the stationary housing. The full bridge circuit is connected directly through the slip rings and brushes to the lead connector which is mounted on the housing of the torque meter.

In version QA torque meters an optical rotation angle measurement system is integrated. It consists of a pulse disk on the rotating shaft with 360 light-dark stripes. Two light barriers are installed into the stator. Inside the torque meter there is a small electronics for processing of the angle pulses.

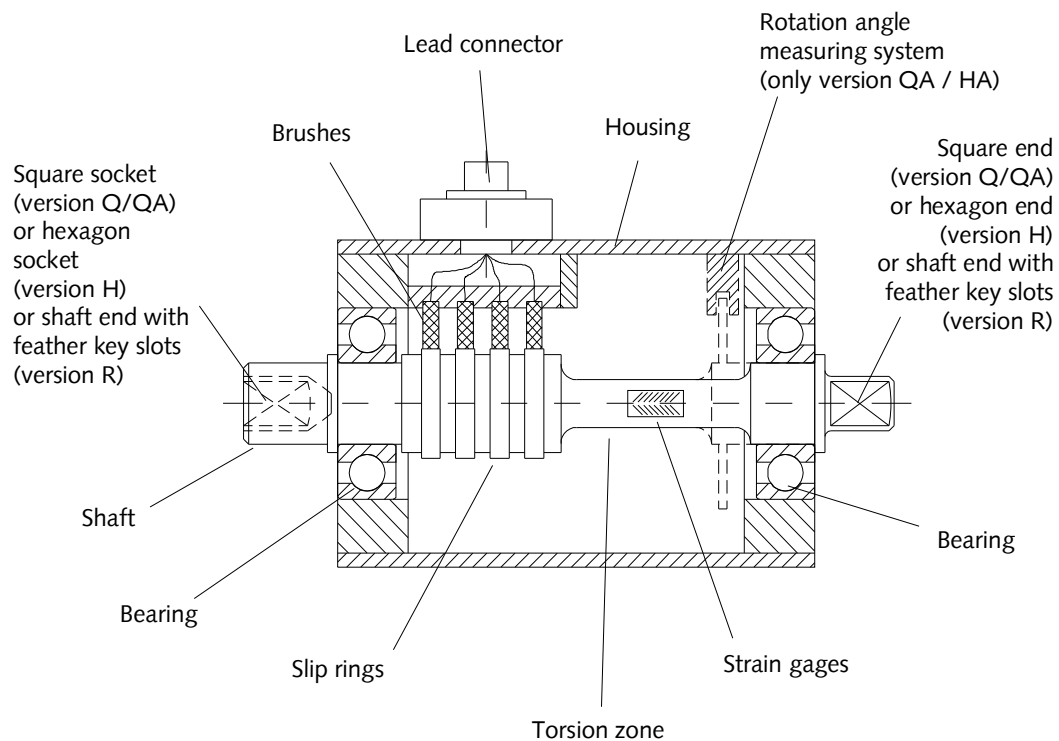
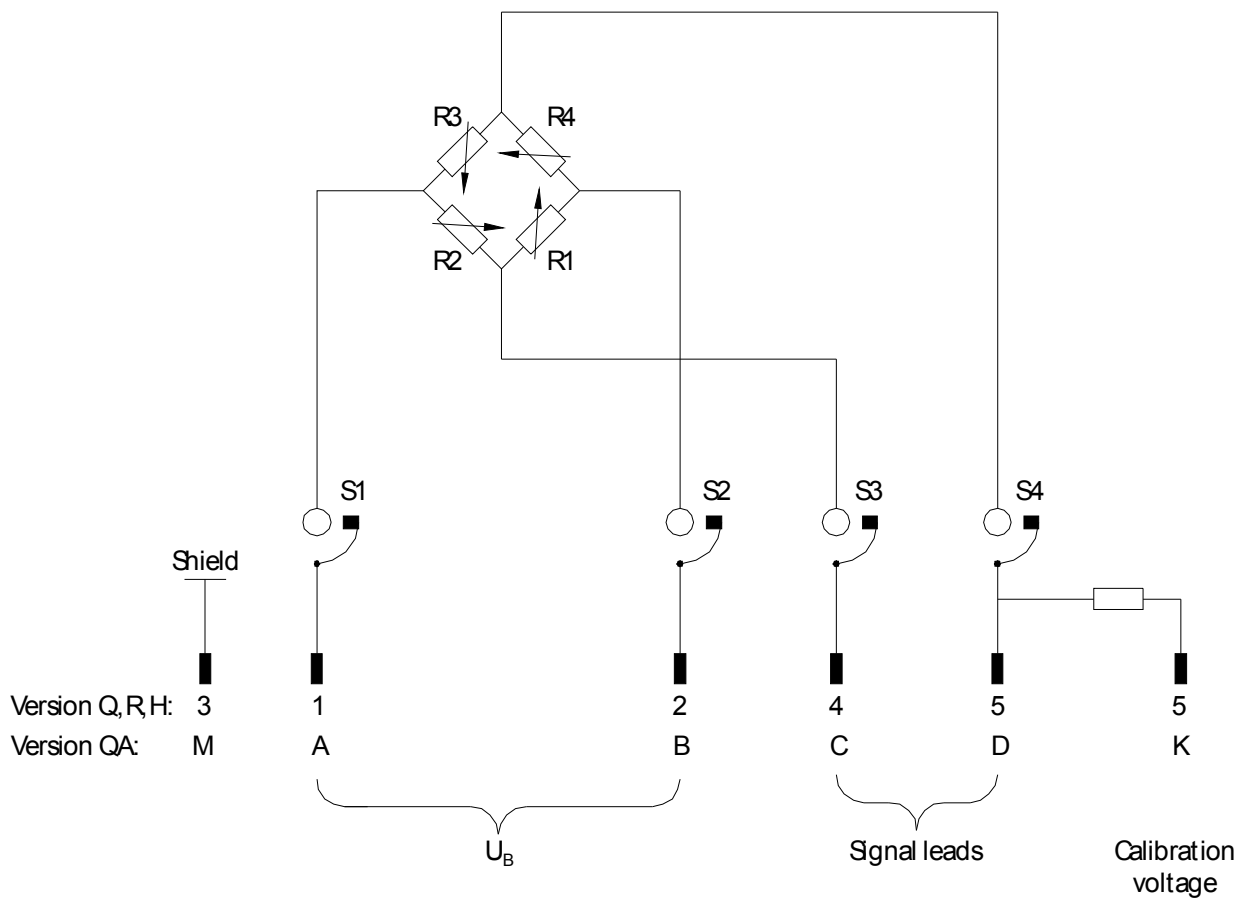

Fig. 1: Mechanical design rotating torque meter Type 4501A...

4.2 Electrical Design



- R1 ... R4 = Gages for measuring mechanical strain
- S1 ... S4 = Slip rings with brushes

Fig. 2: Electrical design

4.3 Rotation Angle Measuring System (Version QA and HA only)

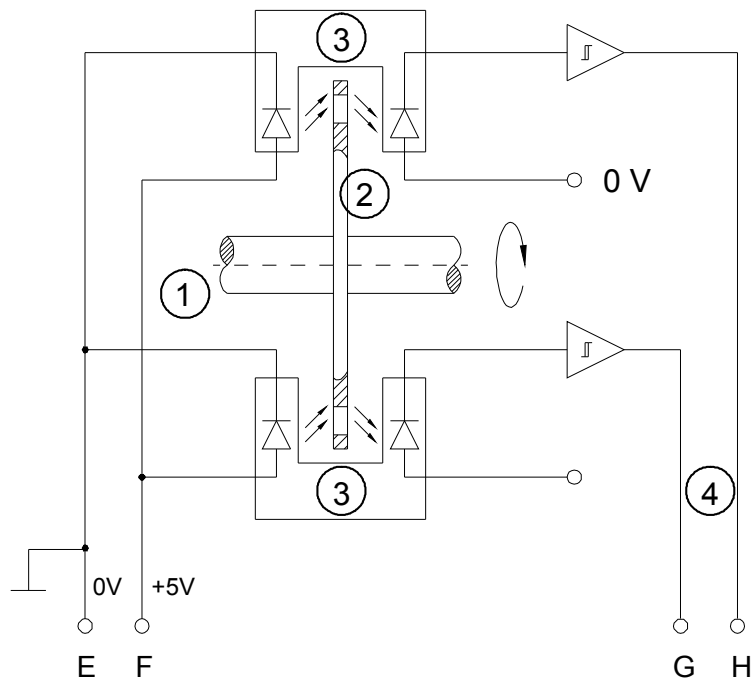

Fig. 3: Diagram showing the design of the rotation angle measuring system

1. Rotating shaft
2. Pulse disk
3. Forked light barrier with LED and photo diode
4. Operation amplifier

Features

- 360 light-dark stripes on the pulse disk
- Two forked light barriers shifted by phase angle 90°
- Pulse number proportional to the rotation angle

Description

Adjustment for angle-pulse output (version QA only).

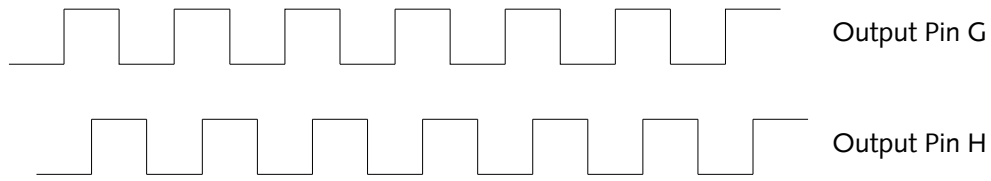

With drive on quare socket
sense of rotation right

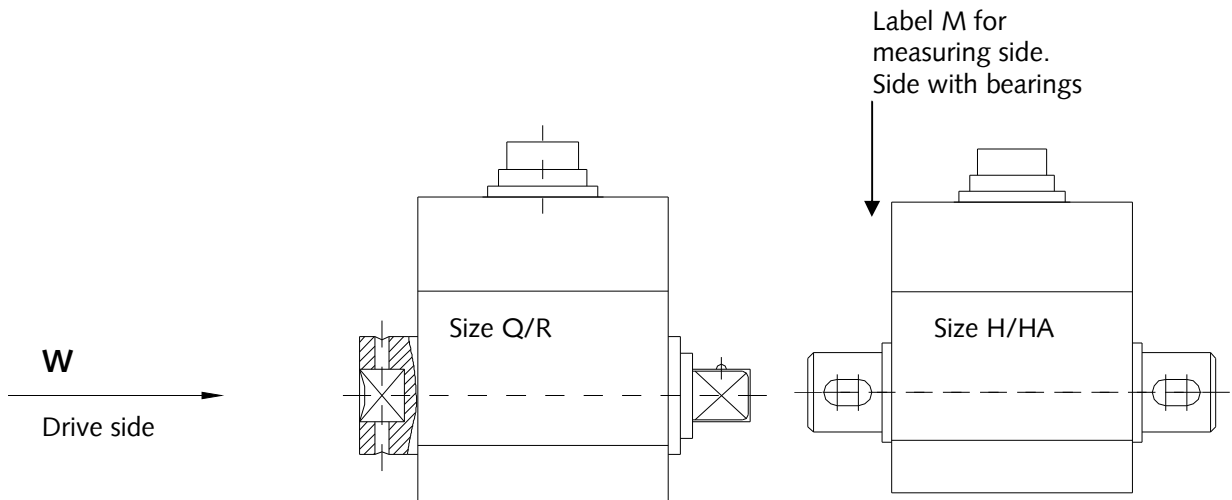

View W:

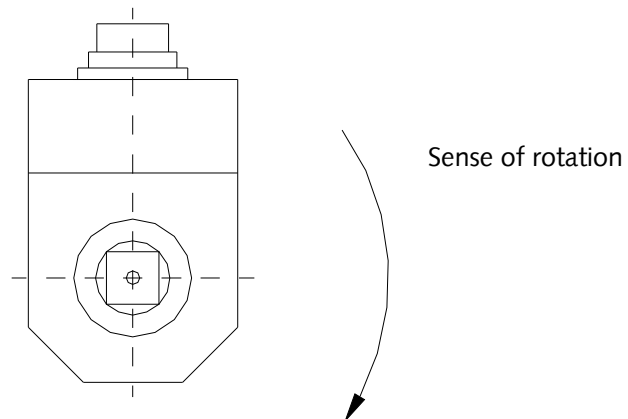

Fig. 4: Adjustment for angle-pulse output

5. Electrical Connections

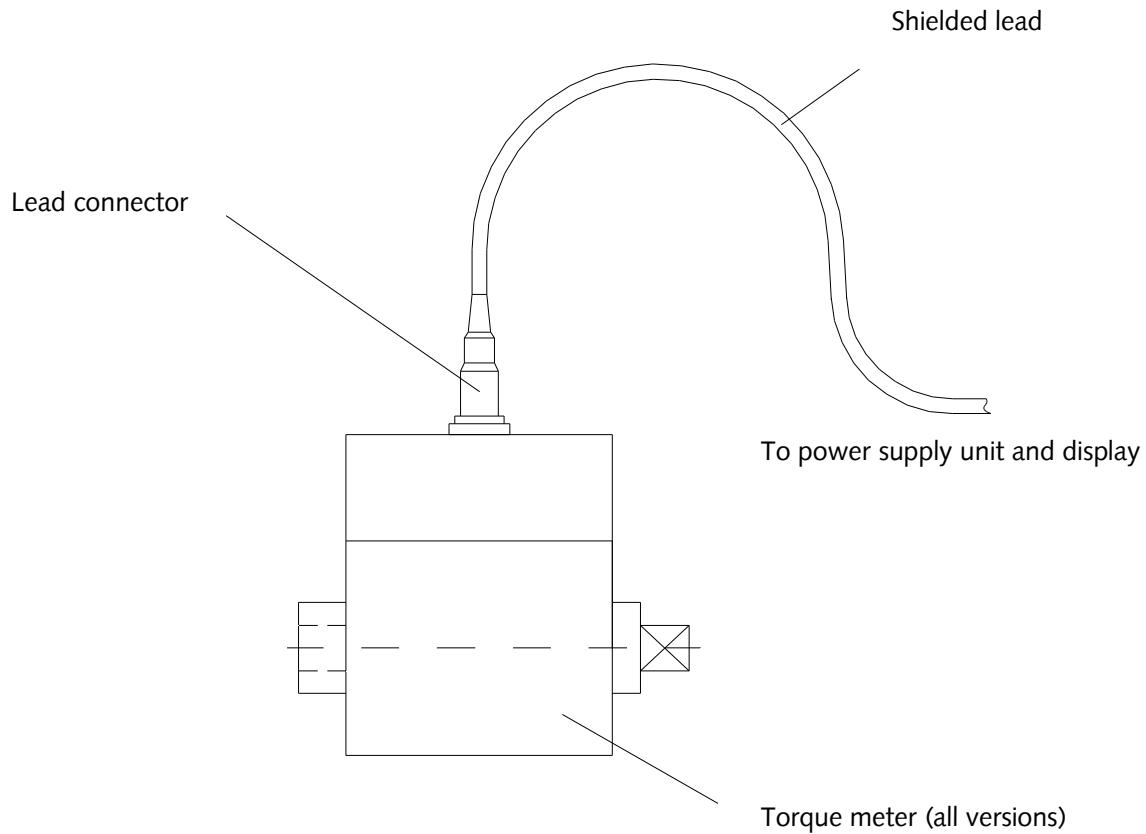

Fig. 5: Electrical connections

- Shielded lead of 0,25 mm² (version X: 0,14 mm²) cross section
- Factory-calibrated with 5 m of lead. A change in lead of 2,5 m will cause an error of approximately 1%

5.1 Description of Interfaces

5.1.1 Versions Q/R/H:

Function	Pin	Description
- Power supply	1	e.g. -6 VDC
+ Power supply	2	e.g. +6 VDC
Shield	3	not connected
+ Signal	4	2 mV/V approx. 350 Ω *)
- Signal	5	2 mV/V approx. 350 Ω *)
- Power supply (Calibration voltage)	6	100% calibration, causes 100% signal

Top view built-in plug

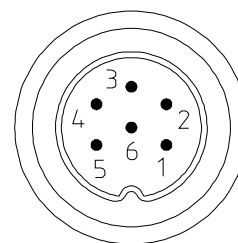

5.1.2 Connection Cable Q/R/H

5.1.2.1 Cable Diagram with Plugs on Both Sides Article-No.: 7186, Versions Q/R/H

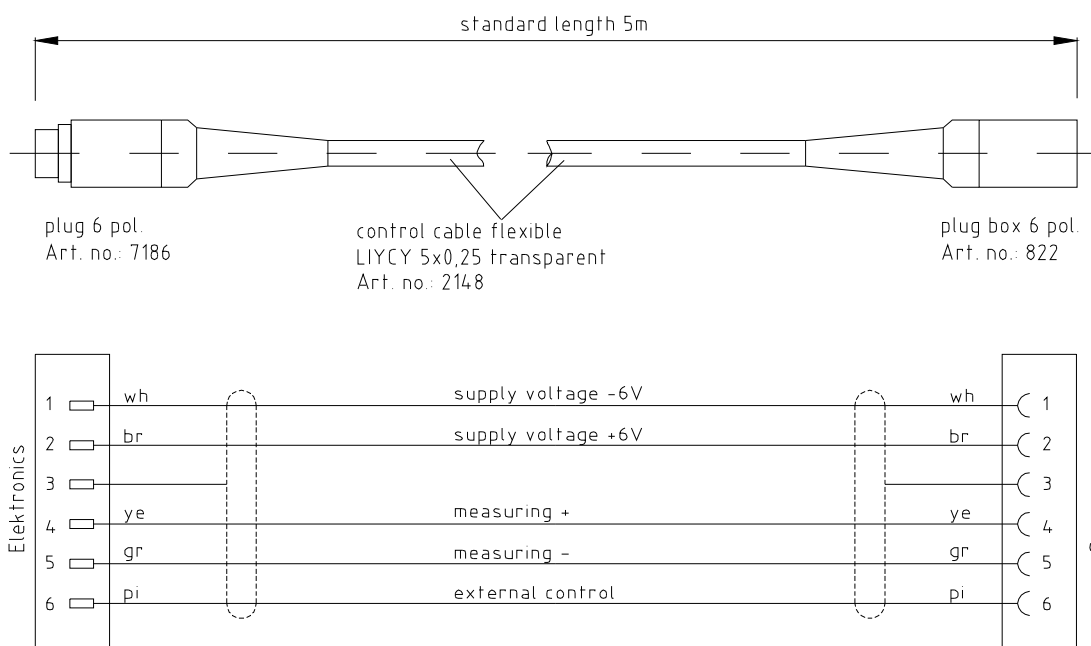

Fig. 6: Cable diagram

5.1.2.2 Cable Diagram, Plug (Transducer), Open Ends Article-No.: 10382, Versions Q/R/H

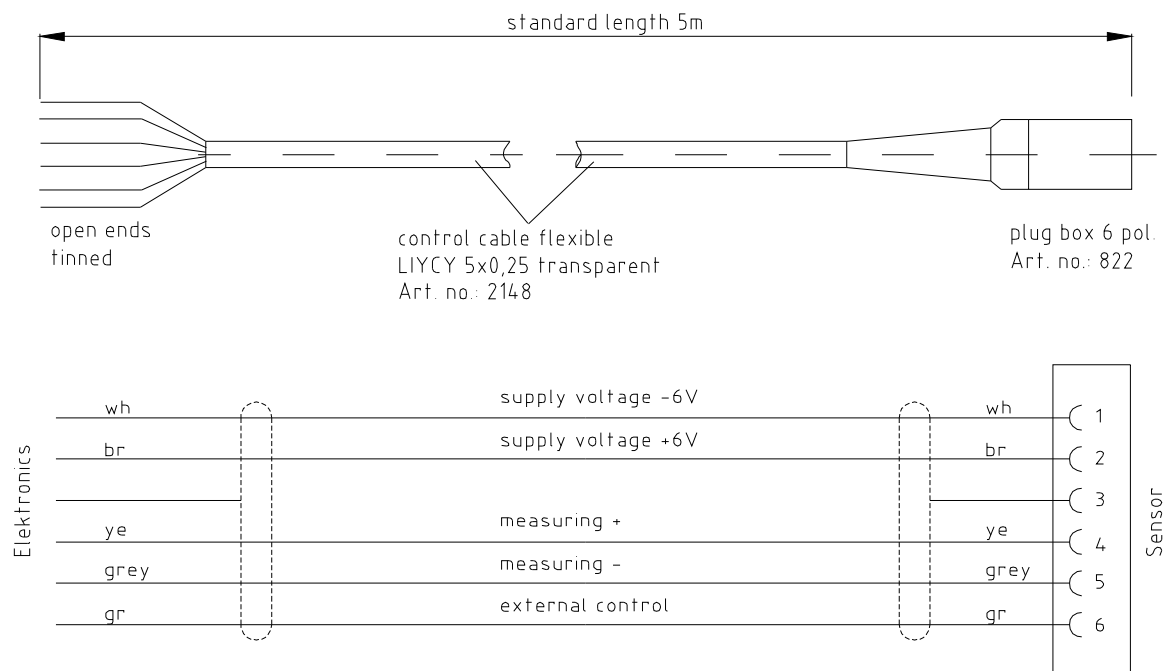
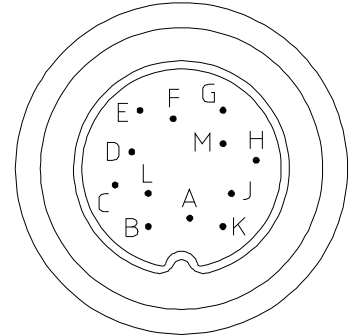

Fig. 7: Cable diagram, plug (transducer), open ends

5.1.3 Versions QA/HA

Function	Pin	Description
- Power supply	A	strain gage full bridge
+ Power supply	B	
+ Signal	C	Rotation angle pulses
- Signal	D	
Angle 0 V	E	0 V
Angle +5 V ±10 %	F	
Pulse l, leading, TTL	G	100% calibration, causes 100% signal not connected
Pulse r, lagging, TTL	H	
- Power supply (Calibration voltage)	K	
Shield	M	

Top view built-in plug



5.1.4 Connection Cables QA

5.1.4.1 Cable Diagram with Plugs on Both Sides, Article-No.: 17069, Version QA

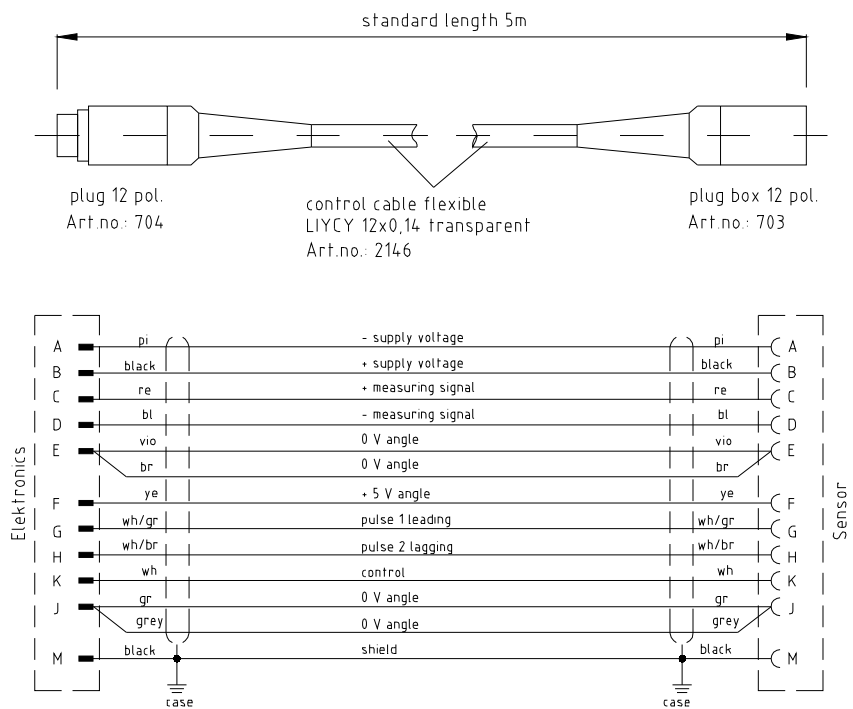

Fig. 8: Cable diagram

5.1.4.2 Cable Diagram, Plug (Transducer), Open Ends, Article-No.: 18315, Version QA

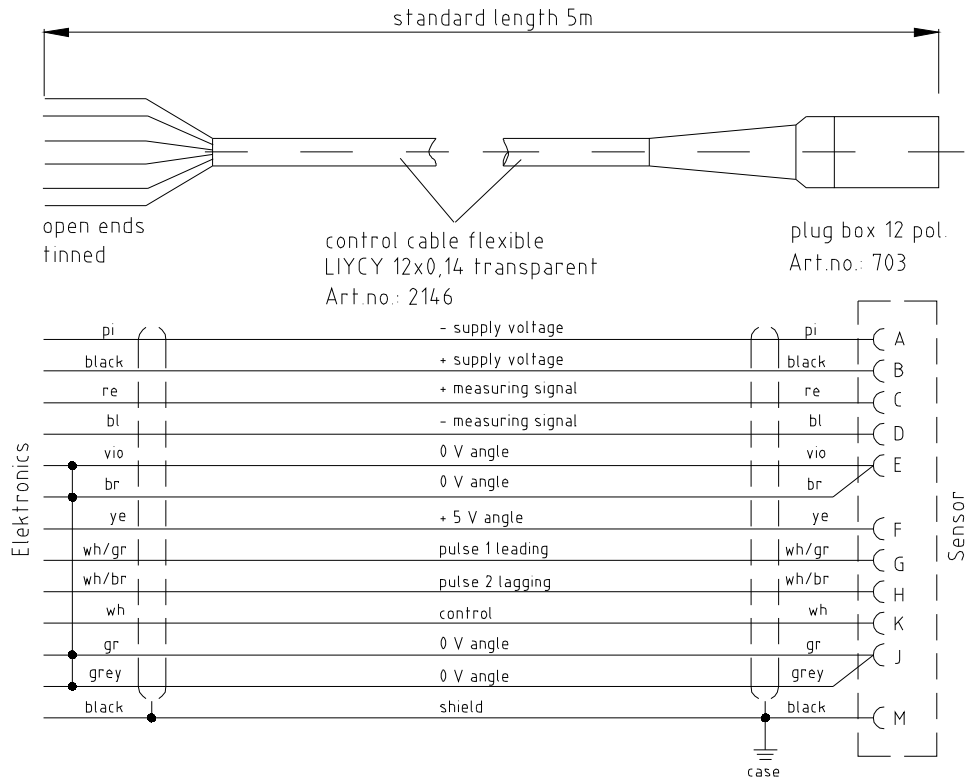

Fig. 9: Cable diagram, plug (transducer), open ends

5.1.5 Version H (Special)

Function

- + Power supply
- Power supply
- Output (measuring signal)
- + Output (measuring signal)
- Shield
- 100% Control (supply)
(Calibration voltage)

Pin

- A e.g. +6 VDC
- B e.g. -6 VDC
- C e.g. 2 mV/V approx. 350 Ω *)
- D e.g. 2 mV/V approx. 350 Ω *)
- E not connected
- F 100% calibration, causes 100% measuring signal

Top view built-in plug

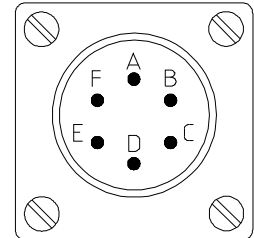

*) Customized, see calibration certificate

5.1.6 Cable Diagram, Plug, Open Ends Article-No.: 7331, Version H (Special)

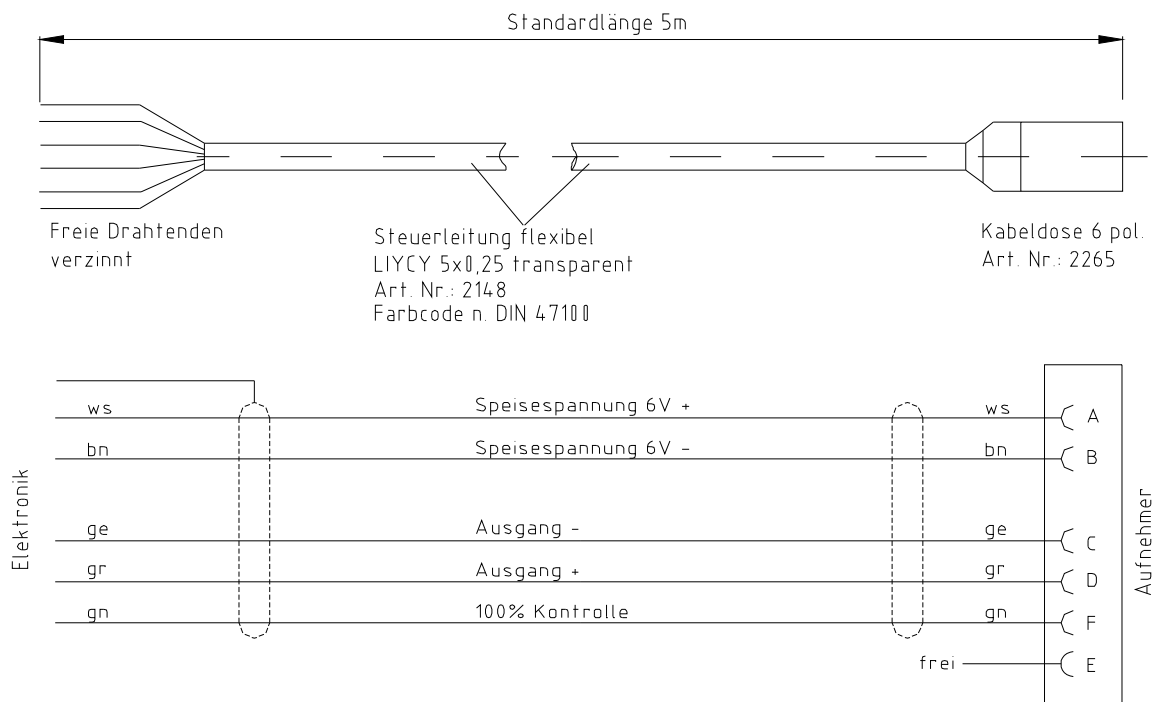

Fig. 10: Cable diagram, plug, open ends

5.2 Installing the Signal Lead

- Do not run the lead parallel to power cables or control circuits
- Do not place the lead close to equipment producing strong electromagnetic fields, e.g. transformers, welders, contactors, electric motors, etc.
- If such situations cannot be avoided, run the lead inside earthed steel conduit
- Make a loop in the lead when fixing it at the torque meter so that it is not damaged by vibration

6. Using the Torque Meter

6.1 Versions Q, QA, H, HA

- Torque meters of version Q and QA have square connections for plug-in tools acc. to DIN 3121
- Torque meter of version H have hexagon connections acc. to DIN 3126, form E/F
- The torque meters are plugged on to the drive spindle as shown below.

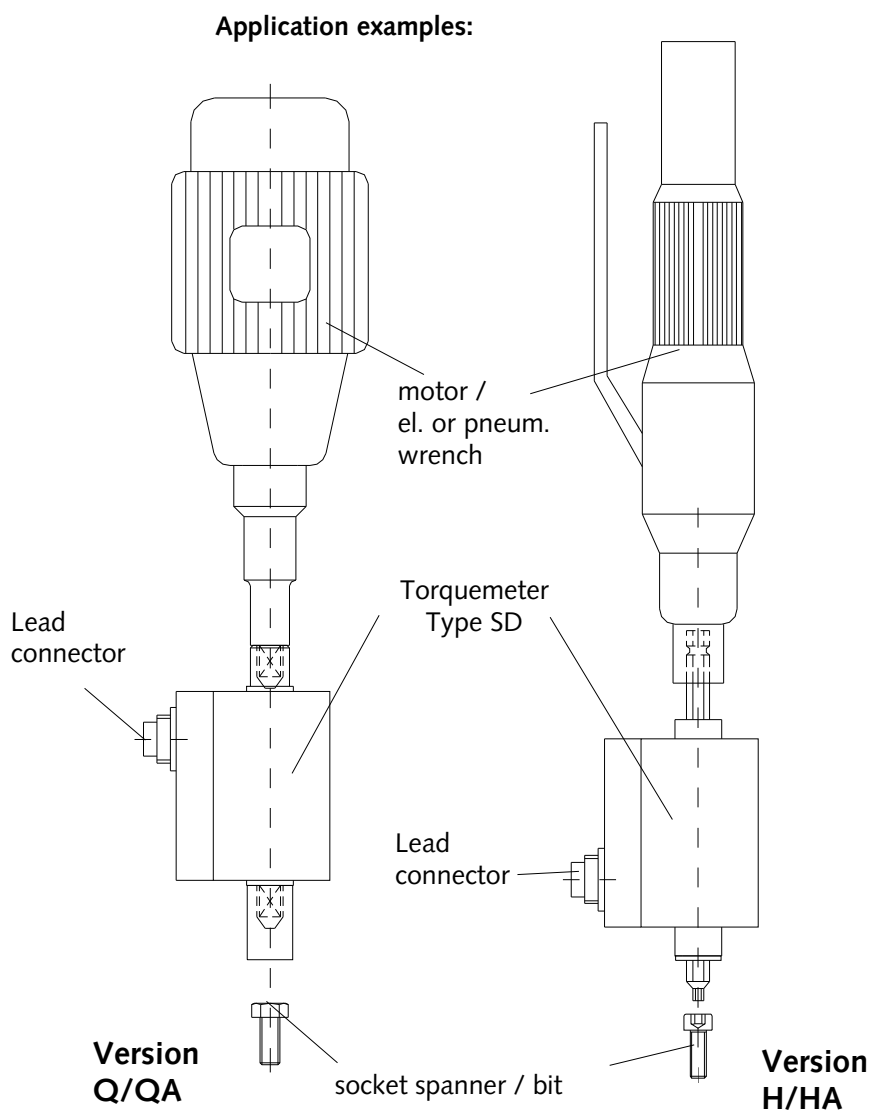

Fig. 11: Application examples versions Q/QA & H/HA

6.2 Version R

- The torque meter is adapted to the measuring application by couplings
- For a free floating installation we recommend two torsionally rigid half couplings

Application example:



Fig. 12: Application example version R

7. Static Calibration

This procedure requires the use of a calibration device with a lever arm and weights for producing specific values of torque.

The calibration procedure is as follows:

- Apply the rated value of torque to the torque meter and then remove it again
- Adjust the zero reading accurately
- Apply a known value of torque to the torque meter.
- Adjust the displayed reading to the corresponding value

Plotting a calibration curve

- Calibrate the torquemeter as described above.
- Apply torque in 1/10 steps up to the full rated value and then remove it again in the same way. A delay of at least 30 seconds must be allowed between the individual 1/10 steps so that each reading can stabilize before it is recorded

7.1 Making a Simple Calibration Device

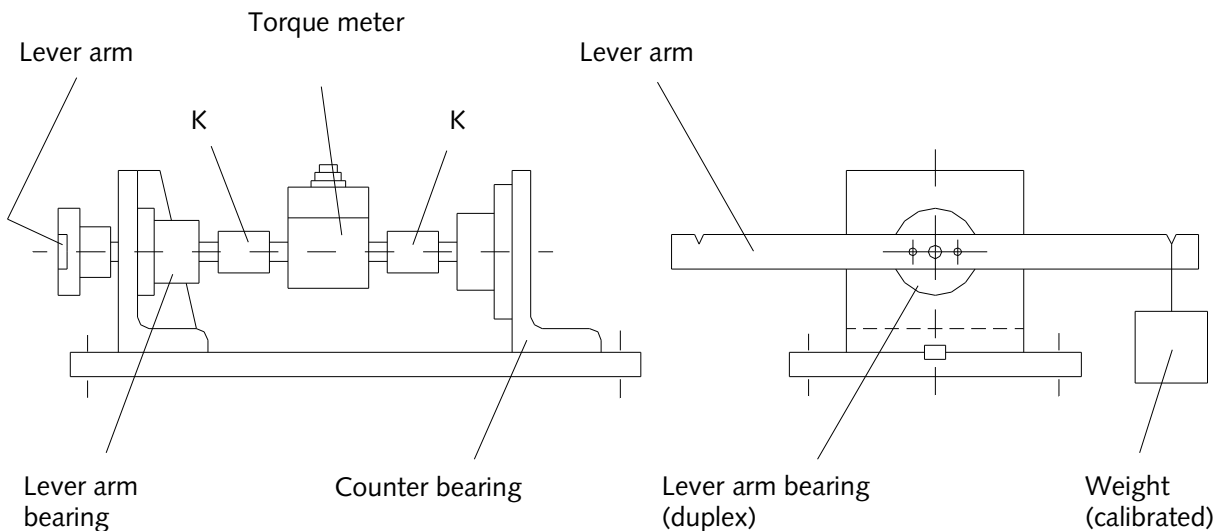

K = Loose half-couplings

Fig. 13: Calibration device

7.2 Calculation Example for Lever Arm Length

$$L = \frac{M}{m \cdot g}, \text{ whereby}$$

- M = Torque
- L = Length of lever arm required
- m = Mass required
- g = 9.80665 m/s²
(= standard gravity – varies with location)

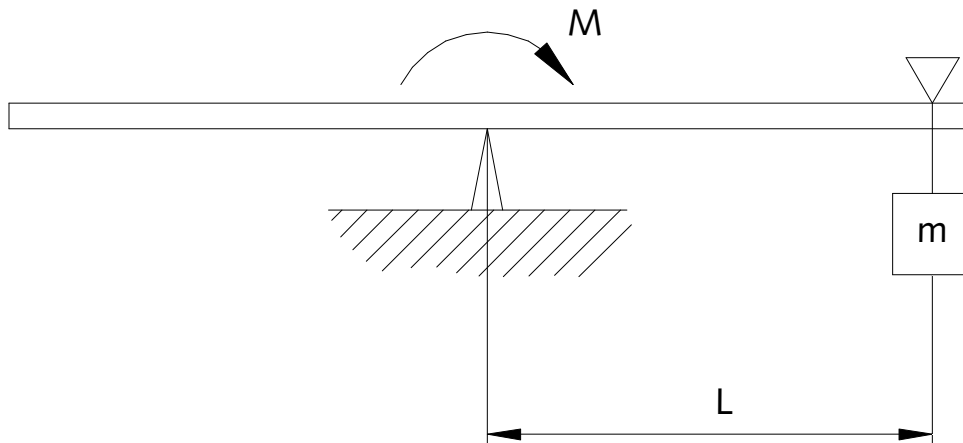

Fig. 14: Calculation of lever arm length

Example: m = 1 kg
M = 10 N·m

$$\rightarrow L = \frac{10 \text{ N} \cdot \text{m} \cdot \text{s}^2}{1 \text{ kg} \cdot 9.80665 \text{ m}} \approx 1.0197 \text{ m}$$

8. Maintenance

- Gradual wear of the brushes and slip rings produces an electrically-conductive dust inside the torque meter which might cause an electrical short between the slip rings and cause instability of the zero reading during rotation. Therefore, it is important to clean the torque meter regularly
- The recommended cleaning cycle is approximately 10^6 revolutions
- In order to clean the interior, loosen the 4 fixing screws and remove the cover plate
- Use a soft linen cloth, a fine hair brush or oil-free compressed air to clean the dust from the slip rings and the spaces between them
- Carefully clean the brushes and the plastic part with the springs using a hair brush or oil-free compressed air
- Version QA+HA: Be careful when cleaning, do not scratch the pulse wheel
- Also clean the lead connector
- Measure the brush thickness; it should be more than 0,5 mm. New brushes can only be fitted at the factory
- Replace the cover plate carefully and re-tighten the fixing screws
- Check the torque meter:
 - Zero reading stable during rotation
 - Produce a torque by twisting the meter by hand and note the reading
- If the torque meter is used for precision work it should be recalibrated every year (either at the factory or by means of a suitable calibration device)

9. Repairs

Fault	Cause	Remedy
Shaft stiff to turn	Bearing defect due to: a) Torsional or flexural vibration b) High axial or radial loads c) Worn bearings d) Bent shaft	Return to factory
Zero shift less than 2%	Torsional vibration Torsional shock	The zero reading can be readjusted at the display
Zero shift between approx. 2 and 5% of full scale	Torquemeter has been over-loaded Torsional vibration Torsional shock	The zero reading can be readjusted once at the display
Hysteresis between clockwise and anticlockwise torque	Torquemeter overloaded by high alternating loads or torsional vibration	Return to factory
Zero unstable during rotation	Slip rings and/or brushes dirty	Open and clean the torquemeter (see section 7)
Angle pulses roll out (only version QA)	Pulse disk and optical sensor are soiled by coal dust	Clean carefully