

**Operating instructions**

**for**

**Thickness Gauge**

**StratoTest 4100 C**

**and**

**Data printer**

**MiniPrint 4100**

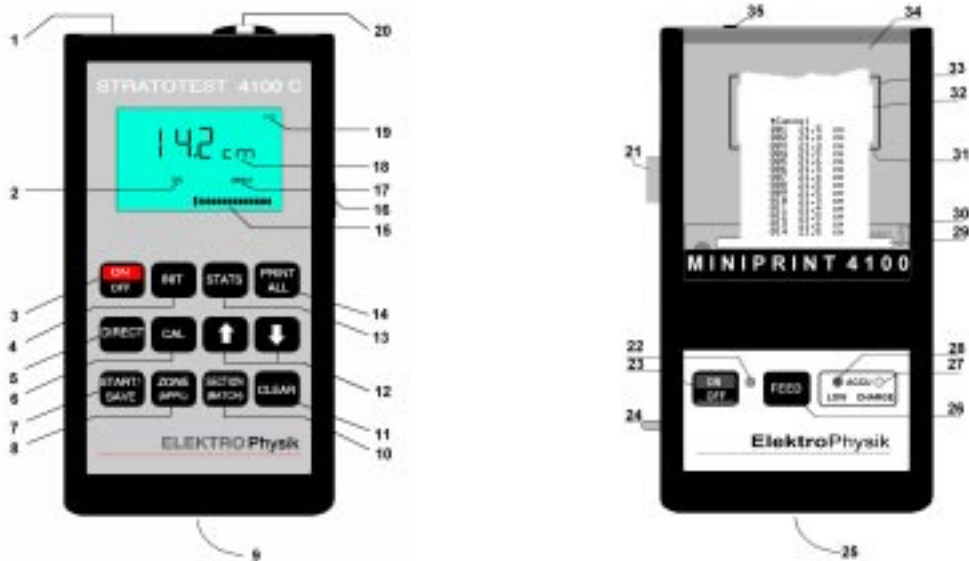

### Legend

1. Power supply socket
2. Note: Calibration is completed
3. On/Off switch
4. INIT-key for activation of the basic settings and special calibrations
5. Key for activating the DIRECT-mode
6. Key for activating calibration
7. Key for activating the measuring mode and for logging the reading to the memory
8. Key for activating the ZONE-SECTION-Mode (APPL)
9. Rear battery compartment
10. Key for selecting a SECTION (BATCH) within a zone number
11. Delete key
12. Arrow keys for adjusting
13. Key to call off statistics
14. Key for printing statistics and measuring values
15. analog bars
16. Interface for data printer MINIPRINT or PC
17. Note: DIRECT-Mode is activated
18. Measuring unit
19. Battery replacement information
20. Probe socket
21. Interface for STRATOTEST 4100 C
22. LED control lamp (green) MINIPRINT 4100 ready to print
23. ON / OFF-key for activating printer function
24. Guide pin
25. Rear battery compartment
26. Paper feed
27. LED-control lamp (yellow) for battery loading
28. LED-control lamp (red) for NiMH-rechargeable battery state
29. Paper roll outlet
30. Printer ribbon
31. Battery compartment below paper roll support
32. Paper roll
33. Support for paper roll
34. Plexiglas cover
35. Socket for battery charger

## Contents

1. Application.....	5
2. Delivery schedule .....	5
3. General operating information for the STRATOTEST 4100 C gauge .....	6
3.1 General Information.....	6
4. Preparing the gauge for operation.....	8
4.1 Mechanical preparation .....	8
4.2 Electrical preparation.....	9
5. DIRECT mode operation .....	10
5.2 General remarks on calibration .....	10
5.3 Calibration .....	11
5.4 Taking a measurement.....	12
5.5 Deleting the last measurement.....	14
5.6 Deleting calibration and activating standard calibration.....	14
5.7 Discontinuing calibration.....	14
5.7 Displaying and printing statistical values individually.....	15
5.9 Deleting statistics.....	16
6. Short instruction for measurements in DIRECT mode .....	16
7. ZONE - SECTION - mode .....	19
7.1 The structure of the ZONE-SECTION system.....	20
7.2 Switching to the ZONE-SECTION mode and calling in the last used ZONE-SECTION memory .....	21
7.3 Selecting an existing or initiating a new ZONE (APPL) - memory column (memory column for calibration).....	22
7.4 Selecting an existing or initiating a new SECTION (BATCH) - memory .....	22
8. Operation in the ZONE-SECTION mode.....	23
8.1 Calibration and measurement in zones with <u>one</u> SECTION.....	23
8.2. Calibration and measurements in zones with <u>several</u> sections .....	24
8.3 Size and form of the metal reflector .....	24
8.4 Calibration .....	24
8.5 Calibration in a particular ZONE .....	25
8.6 Measurement .....	27
8.7 Deleting the last measurement.....	28
8.8 Deleting calibration and activating the standard calibration.....	28
8.9 Discontinuing calibration.....	29
8.10 Individual display and printing of statistical values .....	29
8.10 Printing all single and statistical values .....	31
8.12 Total statistic in SECTION 99 of a ZONE memory column with print out of all single values .....	33
8.13 Printing ZONE-SECTION memory allocation and number of stored measuring values (Directory).....	35

8.14 Deleting a series of readings with their statistical values in a ZONE-SECTION group.....	36
8.15 Deleting all measuring series including statistical and calibration values in one ZONE number.....	37
8.16 Short instruction for measurements using the ZONE-SECTION mode .....	38
9. Initial functions and basic gauge settings .....	40
9.1 TOTAL reset.....	40
9.2 LCD segment test.....	41
9.3 Setting of date and time .....	42
9.4 Basic gauge settings .....	43
10. Calibration and measurement in special applications .....	44
10.1 Measurement of residuary thickness of refractory lining with attached steel sheets .....	<b>Fehler! Textmarke nicht definiert.</b>
10.2 Zero calibration.....	44
11. Trouble shooting.....	46
12. Data printer MINIPRINT 4100 .....	47
12.1 Changing the paper roll .....	48
12.2 Changing the printer ribbon .....	48
12.3 Quick loading function for NiMH rechargeable batteries .....	49
12.4 Printer self test .....	49
13. Connecting a PC (IBM and compatible) .....	49
14. Technical data .....	50

## 1. Application

The gauge STRATOTEST 4100 C - equipped with a 30 cm probe or a 80 cm probe serves for nondestructive measurement of the residuary thickness of refractory bricks and concrete, respectively, in industrial furnaces. The special calibration method allows exact measurement working on the eddy-current principle. The measuring result is not influenced by various properties of refractory bricks as well as by infiltrations occurring in long-term operation.

Even brick linings with integrated steel sheets between the bricks can be measured precisely.

Furthermore, thickness measurement of all electrically insulating materials in layers, e.g. brick, concrete without steel bars, bituminous mixes etc., can be performed.

The metal reflector on which the bricks or the material in layer is applied must have a minimum size of 1m x 1m.

Smaller sizes require a special correcting adjustment. Please contact the manufacturer.

The convex or concave curvature radius of this metal reflector should be more than 2m.

## 2. Delivery schedule

The delivery consists of:

- Gauge STRATOTEST 4100 C with display illumination
- Probe with 30 cm or 80 cm measuring range
- Connection cable for probe and gauge
- Handle
- Data printer MINIPRINT 4100 (optional)
- Plastic case for measuring gauge, printer, probe and accessories
- Operating instructions STRATOTEST 4100 C

### 3. General operating information for the STRATOTEST 4100 C gauge

The gauge works on the eddy-current principle and allows non-destructive measurement of electrically insulating materials in layer situated above a metal reflector. The metal reflector can be made of steel as well as of nonferrous metal.

Measurement of the residuary brick thickness in industrial furnaces with steel sheets between the bricks is also possible.

The STRATOTEST 4100 C gauge offers two operating modi: the **DIRECT**-mode and the **ZONE-SECTION**-mode.

The '**DIRECT**-mode' serves for simple, fast and incidental measurements with statistic evaluation and immediate print-out of the measuring values. Single values are not stored when working in this mode. Statistical values which are evaluated by the gauge automatically can be displayed and printed by pressing the 'STATS'-key. The statistics are evaluated from max. 9999 values.

The **ZONE-SECTION**-mode allows calibration, measurement and storage of measuring values in a memory which can be defined by the operator. More than 10 000 readings and more than 500 separate series of measurements can be stored and evaluated statistically.

If a portable data printer MINIPRINT is connected to the gauge, all single readings and the statistical values can be printed out. The data printer is laterally hooked to the gauge and is immediately ready for operation.

#### 3.1 General Information

##### Switch off gauge

Three minutes after the last reading has been taken, the gauge switches off automatically (factory preset basic setting, see 9. and 9.4). However, it can be switched off with the ON/OFF-key before the automatic switch off.

If the automatic switch off is not activated, the gauge works in long-term mode and needs to be switched off manually. The automatic switch off can be a hinder in certain situations. The gauge can thus be switched to the long-term mode.

(See "9.4 basic gauge settings")

Note: The following data is preserved after switching the gauge off and on again:

- the last calibration
- the stored measuring values
- the basic settings



## 4. Preparing the gauge for operation

### 4.1 Mechanical preparation

Insert the shaft of the telescopic support into the central hole of the plate-shaped or wheel-shaped probe and fasten with screws. Connect the probe and the gauge with the enclosed cable and if necessary hook the cable in the cable cramps.

#### STRATOTEST 4100 C with probe F300ST

The height of the telescopic support can be adjusted by turning the locking sleeve (loosen the lock clockwise). The telescopic draw-out of the handle is secured against falling out.

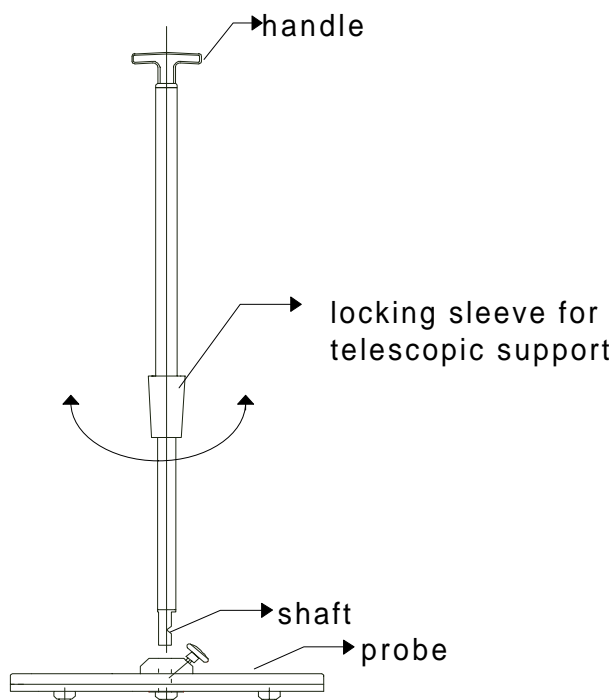

Probe F300ST

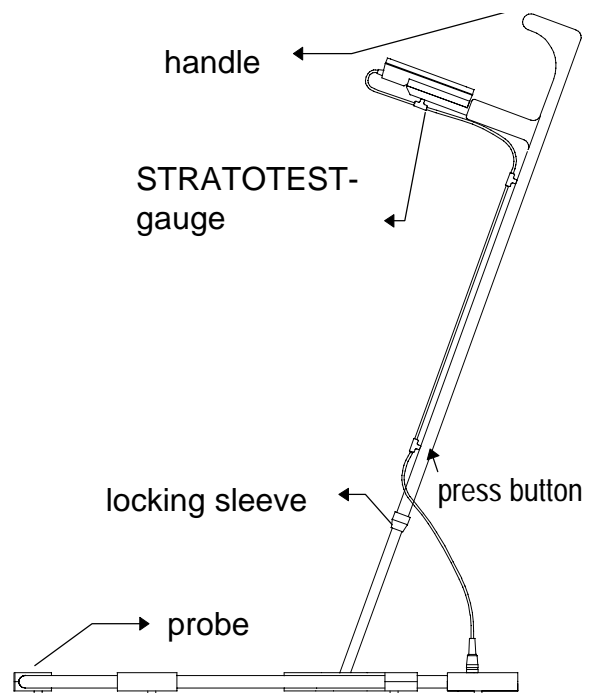

Probe F800ST

#### STRATOTEST 4100 C with probe F800ST

Loosen the locking sleeve and adjust to the correct height with the press-button hold down. Fix the gauge to the handle by means of the velcro fastener.

## 4.2 Electrical preparation

### Power supply:

The STRATOTEST 4100 C gauge is operated with a 9 Volt Alkaline-battery or a 9 Volt rechargeable battery. The manufacturer recommends rechargeable battery operation.

Check battery condition by pressing ON

- No LC display: battery or rechargeable battery missing or battery charge too low to activate the gauge;
- No BAT display\* : battery is sufficiently charged;
- flashing BAT display, gauge switches itself off after about 1 sec: replace battery immediately;
- If the BAT display flashes during measurements, the battery is running low and should be replaced before the gauge is switched on next time.

\*battery symbol in the upper right corner of the display

Note that the gauge will not make faulty measurements even if the voltage is very low.

Replacing the battery:

The rear battery compartment can be opened by unfastening the two screws.

When inserting new battery, make sure the positive and negative poles are correctly positioned. If not, all data saved to memory will be lost.

An interval of more than 10 seconds between removing the old battery and inserting the new one will also result in the loss of data.

## 5. DIRECT mode operation

### 5.1 Size and form of the metal reflector

The metal reflector which serves for measuring the brick thickness must have a minimum size of 1m x 1m. The convex or concave curvature radius should be at least 2m at the measuring area.

Measurements taken on smaller measuring areas or smaller curvature radii increase the uncertainty of measurement.

### 5.2 General remarks on calibration

Calibration requires only one thickness value serving as reference which can be found out by means of a test drilling.

The electromagnetic influences which can be exerted on the probe by different types of bricks, materials in layer or steel sheets between the bricks are eliminated by calibration. It is thus recommended to take a test drilling in each type of brick used in the furnace. This test drilling provides two important informations:

1. a change in quality in the brick consistency after a certain time of usage and before;
2. the residuary brick thickness. The latter is measured with a rule up to the reflector. This measuring value is taken as calibration value for the calibration described in 5.3. The mechanical measurement of the residuary brick thickness should thus be carried out carefully.



In case a measurement is taken on a curvature radius smaller than 2m, a zero calibration is necessary in order to improve the accuracy. The "zero calibration" serves for a geometrical correction. Normally, a "zero calibration" is not necessary when measuring in rotary kilns. If a "zero calibration" must be carried out, this should be done on an uncoated metal sheet of at least 1m x 1m which has the same curvature radius as the measuring object (see 10.2 zero calibration).

5.3 Calibration

1. Determine the residuary brick thickness (calibration value) by means of a test drilling









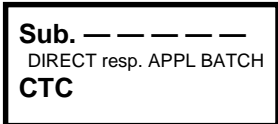

Key selection

Display

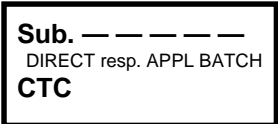
2.  Switch on gauge if not yet switched on.
3.  The gauge switches to DIRECT mode. 

Depending on the lining type of the fireproof bricks, with or without installed steel sheets, the gauge must be set to the required type of brickwork.

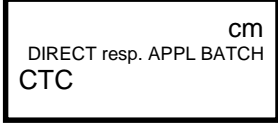
When the lining type 'with installed steel sheets' is selected, CTC (Coating Thickness Correction) is displayed

4. 
5.  The selected lining type is displayed. 
6.  Selecting the lining type **without** installed steel sheets. 
7.  Selecting the lining type **with** installed steel sheets.. 
8.  The lining type is selected. 'CTC' is shown on the display when the lining type '**with** installed steel sheets' was selected (Coating Thickness Correction ). 
9.  The calibration mode is initialized. INF (infinite = ∞) is displayed provided the probe is lifted. 



3. **Place the probe on the bricks.**  
 The bricks must be free from coating. The residuary brick thickness, i.e. 12,5 cm is displayed. Depending on the residuary brick thickness an analog bar of corresponding length is displayed. In case of installation of steel sheets between the bricks the lowest measuring value must be found.
4.  The probe being placed on the bricks the displayed reading is logged to the memory and printed provided that a printer is connected to the gauge.
5. For the next measurement start at step 2  
 START key

CAL	12.5 cm DIRECT
-----	-------------------

CAL	12.5 cm DIRECT
-----	-------------------

**Note:** Closure shims

In case an unexpectedly low measuring value is displayed, the probe can be positioned near or above a closer shim. The measuring value displayed is false. The measurement should be repeated in a distance of at least 0,5m from the closer shim.

### 5.5 Deleting the last measurement



If a faulty reading was logged to the memory by pressing the START/SAVE key accidentally, this measuring value can be deleted immediately by pressing the CLEAR key.

A short bleep confirms the last registered value has been deleted.



### 5.6 Deleting calibration and activating standard calibration

The standard calibration is not appropriate for the thickness measurement of bricks or other materials in layers. The standard calibration serves only to air-measure the distance to a metal reflector of >1m x >1m.

#### Deleting calibration

	Key selection		Display
1.		Switch on gauge if not yet switched on.	
2.		The gauge switches to DIRECT mode.	
3.		The calibration mode is initiated. INF (infinite = ∞) is displayed provided the probe is lifted.	flashing
4.		Press CLEAR. The standard-calibration is activated.	

### 5.7 Discontinuing calibration

If the CAL key is pressed once or twice by mistake, calibration is activated unintentionally.









Unintentionally activated calibration can be discontinued after the first or second pressure of the CAL key by switching the gauge off.

The former calibration remains unchanged.

## 5.7 Displaying and printing statistical values individually

Provided that a data printer MINIPRINT 4100 is connected to the gauge and switched on (ON-LINE) (see "12. Data printer"), the statistical values are displayed after key stroke and printed simultaneously.

The statistical values are transmitted to a PC provided the gauge STRATOTEST 4100 C is connected to a PC with an RS 232 cable and the adequate PC program is activated.

	Key selection	Display
1.	 Switch on gauge if not yet switched on	
2.	 The gauge switches to DIRECT mode.	
3.	 .	<b>N</b> : number of measuring values
4.		<b>MEAN</b>
5.		<b>STD.DEV.</b> : standard deviation
6.		<b>KVAR</b> : variation coefficient (STD.DEV / MEAN)
7.		<b>MAX</b> : highest single value
8.		<b>MIN</b> : lowest single value

Press START/SAVE to discontinue the statistics and take the next reading.







### Note:

The statistical values can be called in whenever you choose, even after each stored measurement.

### 5.9 Deleting statistics

Caution! This action deletes all statistical value in the DIRECT mode.

The calibration is not deleted.

	Key selection		Display
1.		Switch on gauge if not yet switched on (Should "APPL" appear on the display, press DIRECT).	
2.		number of measuring values, e.g. 12.	
3.		Statistics are deleted.	

### 6. Short instruction for measurements in DIRECT mode







Calibration, measurement and storage







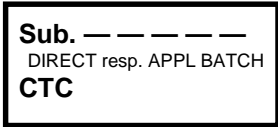

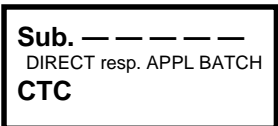
#### Calibration

Key selection

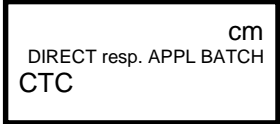
1. **Determine the residuary brick thickness (calibration value) by means of a test drilling.**

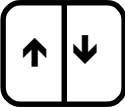
This reference position must be free from coating.

2.		Switch on gauge if not yet switched on.	
3.		The gauge switches to the DIRECT mode.	
4.		Selection of the lining type.	
5.		The selected lining type is displayed.	flashing 
6.		Selecting the lining type <b>without</b> installed steel sheets.	blinkt 

7.  Selecting the lining type **with** installed steel sheets. flashing 
8.  The lining type is selected. 'CTC' is shown on the display when the lining type '**with** installed steel sheets' was selected (Coating Thickness Correction ). 
9.  The calibration mode is initialized. INF (infinite =  $\infty$ ) is displayed provided the probe is lifted.
10. **Place the probe on the reference position**  
The reference position must be free from coating.  
In case of installed steel sheets between the bricks the probe must be moved over the surface until the lowest measuring value is displayed.
11.  The measuring value at the reference position is taken over by the gauge, the probe can be lifted.
12.  Adjust the calibration value of the test drilling.
13.  The calibration value is saved. The calibration is completed.
- Measuring**
14.  The gauge switches to measuring mode. [- - - - **cm**] is displayed. 
15. Place the probe on the clean brick surface. The residuary brick e.g. 12,5 cm is displayed. Depending on the residuary brick thickness an analog bar of corresponding length is displayed. In case of installed steel sheets between the bricks the probe must be moved over the surface until the lowest measuring value is displayed. 

**Storage**

16.



the displayed measuring value is saved provided that the probe is still placed on the bricks.



17. Start again at step 14 'Measuring' in order to take the next measurement..

## 7. ZONE - SECTION - mode

Zone = ZONE memory in longitudinal direction of the oven (lining field)

Section = SECTION memory

The following chapter 7 describes:

- the function of the ZONE-SECTION mode
- the structure of the ZONE-SECTION memory system
- the switch from DIRECT to ZONE-SECTION mode
- the selection of individual memories in the ZONE-SECTION mode
- the input of calibration values
- the special features of the ZONE-SECTION memory system.

### **Note:**

The keys ZONE (APPL) and SECTION (BATCH) serve to select the required memory.

APPL and BATCH appears on the display.

Operation in the ZONE-SECTION mode, e.g. calibration, measurement etc. is only possible if “APPL“ and “BATCH“ appear on the display. If not a ZONE-SECTION memory needs to be selected with the keys ZONE-(APPL) and SECTION- (BATCH) (see 7.4 and 7.5).

Gauge status after switch on:

- The gauge is switched to the mode of the last operation, i.e. either the DIRECT mode or the ZONE-SECTION mode.
- If the gauge is switched to ZONE-SECTION mode, the last ZONE-SECTION memory is activated.
- Calibration values and statistical values are stored. .
- The ZONE-SECTION mode allows to continue the measuring series if the gauge was calibrated formerly.
- If all data are deleted, only the measuring unit is displayed [ cm ].

### **Note:**

1. The statistical data remain in the DIRECT mode after switching to the ZONE-SECTION mode.
2. After pressing the ZONE key the number of the last used ZONE-SECTION memory is displayed.
3. Three minutes after the last measurement was taken, the gauge switches off automatically.
4. The gauge also switches off automatically if the probe is disconnected after starting the measurement (START/SAVE key).

## 7.1 The structure of the ZONE-SECTION system

The ZONE memories (APPL) with their SECTION memories (BATCH) allow:

- storage of calibration values for different linings in the ZONE memories;
- storage of single values of measuring series;
- statistical evaluation of measuring series within SECTION memories (see figure).

The SECTION memory (BATCH) no. 99 is locked so that no single values can be logged to the memory.

Selecting print within the SECTION memory no. 99 effects that a statistic of all measuring values in all SECTION memories 1-98 within one ZONE-memory-column is calculated and printed out via a printer or PC, respectively.

Figure: ZONE-SECTION-memory

		ZONE-memory-columns(APPL)					
		1	2	3	97	98	99
SECTION-memory (BATCH)	1	1	1	2	1	3	1
	2	1	2	2	2	3	2
	3	1	3	2	3	3	3
	97	97	1	98	1	99	1
	98	97	2	98	2	99	2
	99	97	3	98	3	99	3
	97	1	97	2	97	97	3
	98	1	98	2	98	98	3
	99	1	99	2	99	99	3

The STRATOTEST 4100 C offers 99 ZONE memories (ZONE-SECTION-memory fields) - with 98 SECTION memories each. This totals to 9702 memories all in all; max. 500 of these can be initialized for different series of measurement. Up to 10 000 measuring values can be stored.

An increasing amount of initialized ZONE-SECTION fields reduces the maximum amount of storable measuring values.

### **ZONE-memory column (APPL)**

(only for storage of calibration values)







Each of the 1 to 99 ZONE memories serves for storage of one calibration, i.e. calibrations for different linings of the furnace. A calibration once performed within a ZONE memory column does not need to be repeated within one series of measurement; calling in the corresponding ZONE number is sufficient. The measurement within the selected SECTION of this field of lining can be started immediately.

**SECTION memory (BATCH)**

(for storage of measuring values)

The ZONE memories are subdivided in SECTION memories. Measuring series with the same calibration can be logged into these SECTION memories and can be evaluated statistically. The subcolumn in various SECTION memories allows individual judgment of the brick thickness in different sections whose measuring values are all based on the same calibration.

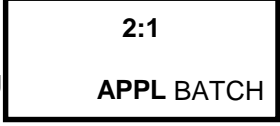







**7.2 Switching to the ZONE-SECTION mode and calling in the last used ZONE-SECTION memory**

- |    | Key selection   |  | Display   |
|----|---|--|---|
| 1. |    | Switch on gauge if not yet switched on .           |    |
|    |   |  | or  |
|    |   |  |    |
| 2. |  | Last selected memory is displayed e.g. [ 2:1 ].    |  |
| 3. |  | Confirming the last memory displayed e.g. [ 2:1 ]. |  |
| 4. | Calibrate or measure if necessary (see. 8.5 or 8.6)                                 |  |   |

**Note:**

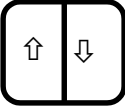
A calibration which was already performed is indicated by [ CAL ].









### 7.3 Selecting an existing or initiating a new ZONE (APPL) - memory column (memory column for calibration)

	Key selection		Display
1.		Switch on gauge if not yet switched on.	
2.		Last selected memory is displayed e.g. [ 2:1 ].	flashing 
3.		Select ZONE number e.g. [ 5:1 ].	flashing 
4.		Confirm selected number	not flashing 
5.		Calibrate or measure if necessary (see. 8.5 or 8.6)	

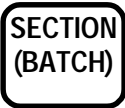
#### Note:

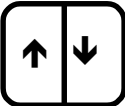
A calibration which was already performed is indicated by [ CAL ].

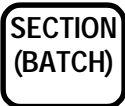
### 7.4 Selecting an existing or initiating a new SECTION (BATCH) - memory

	Key selection		Display
1.		Switch on gauge if not yet switched on. The gauge must be switched to the ZONE-SECTION mode (display: [APPL BATCH]).	
2.		Last selected memory is displayed e.g. [ 5:1 ].	flashing 
3.		Select new SECTION number e.g. [ 5:2 ].	flashing 
4.		Confirm memory displayed	not flashing 
5.		Calibrate or measure if necessary (see. 8.5 or 8.6)	

**Note:**

1. A calibration which was already performed is indicated by [ CAL ].
2. Holding the arrow keys down when selecting a new SECTION memory, leads to a faster display of the seized memories. The display of memory numbers is stopped as soon as it reaches the first free SECTION memory. Press the arrow key anew for further memory numbers.

**8. Operation in the ZONE-SECTION mode**

**8.1 Calibration and measurement in zones with one SECTION**

The following illustration of the unwinded lining of a rotary kiln serves to illustrate the following: The furnace is subdivided in zones in longitudinal direction. The measuring position is marked by the running number of the measuring value in the SECTION 1 memory. In below example 12 measuring values are stored in each zone. The running number is allocated to a certain place or angle at the circumference. In below example the operator selects only a zone e.g. 3 and thus SECTION 1 (3:1) at the same time. The series of measurements can be taken and the individual running numbers indicate the position for each single reading.

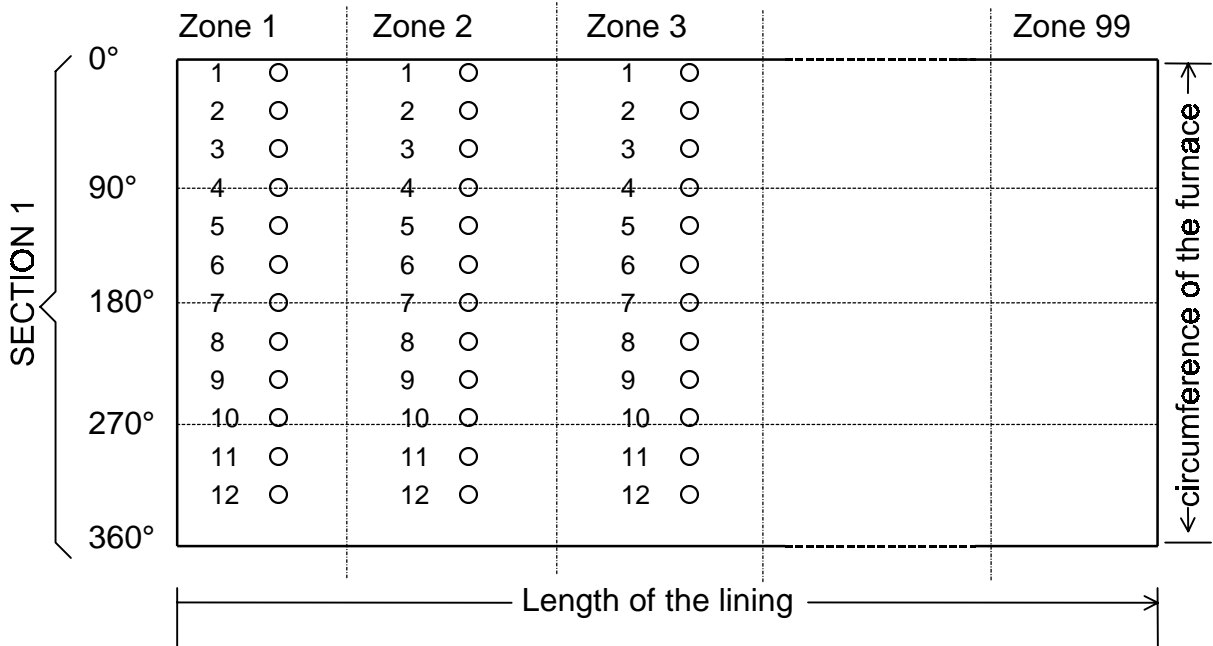

## 8.2. Calibration and measurements in zones with several sections

In the following illustration the surface area of the kiln is subdivided in zones and sections. Having selected a ZONE, a particular section number can be selected, e.g. 2:3, i.e. ZONE 2, SECTION 3. Different measuring values, e.g. six measuring values, can be taken in this field at different points (operator selectable). The maximum amount for sections to be entered is 98.

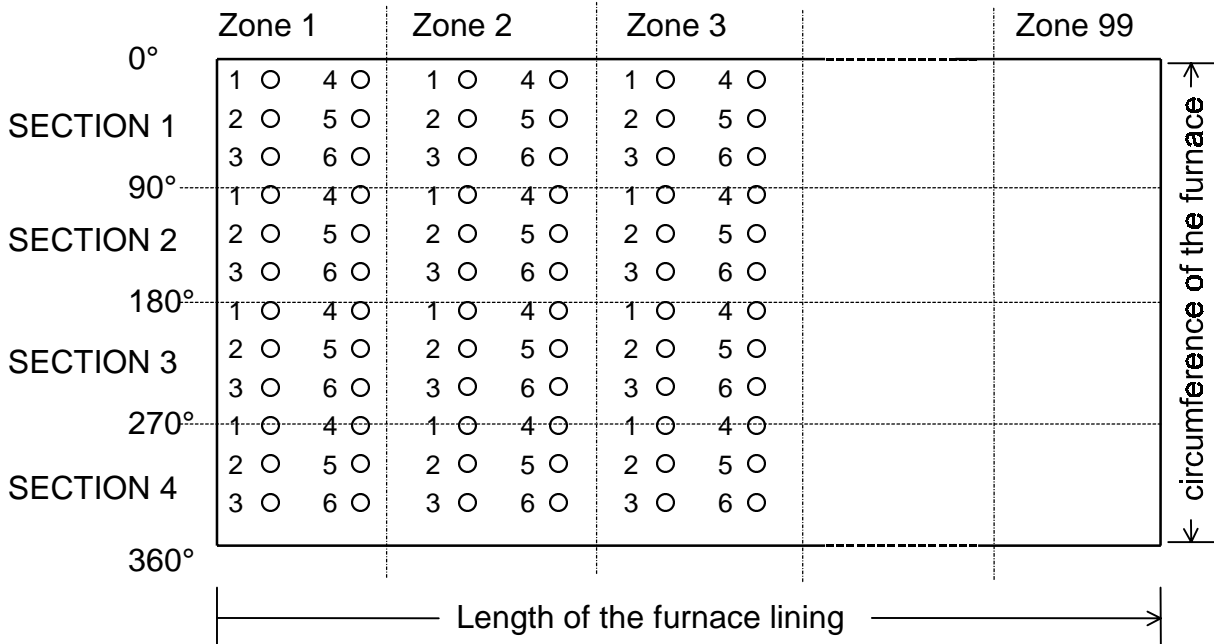

## 8.3 Size and form of the metal reflector

The metal reflector which serves for the brick thickness measurement must have a minimum size of 1m x 1m. The convex or concave curvature radius should be more than 2m at the measuring point.

Measurements on smaller reflectors or smaller curvature radii lead to a deterioration in accuracy.

## 8.4 Calibration

Calibration only requires a reference thickness which can be determined by means of a test drilling.

Calibration serves to eliminate the ferromagnetic influences exerted on the probe which can occur as a result of different types of bricks or materials as well as of steel sheets which are installed between the single bricks. It is thus recommended to take at least one test drilling in each type of brick used in the furnace in order to perform a correct calibration. This test drilling provides two important information's:

1. a change in quality in the brick consistency after a certain time of usage and before and
2. the residuary brick thickness: The latter is measured with a rule up to the reflector. This measuring values is taken as calibration value for the calibration described in 5.3. The mechanical measurement of the residuary brick thickness should thus be carried out carefully.

**Note:**

Measurements on surfaces with a curvature radius smaller than 2m require a zero calibration (see 10.2). In this case the guaranteed uncertainty of measurement is no longer valid. The "zero calibration" serves for correcting the geometry. As a rule, "zero calibration" is not necessary when measuring rotary kilns. If a "zero calibration" is required, this calibration must in any case be performed on an uncoated metal reflector of a minimum size of 1m x 1m with the same curvature radius as the measuring object.









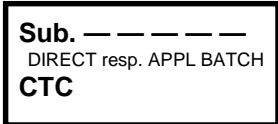

### 8.5 Calibration in a particular ZONE

Calibration is always carried out for one 'ZONE' being valid for all sections within this ZONE.

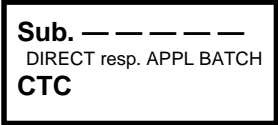

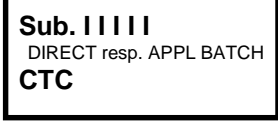
1. **Determine the residuary brick thickness (calibration value) by means of a test drilling**
2. The requested ZONE (APPL) memory is already set (see 7.3).

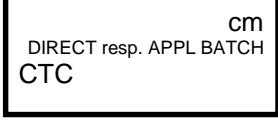
Depending on the lining type of the fireproof bricks, with or without installed steel sheets, the gauge must be set to the required type of brickwork.

When the lining type 'with installed steel sheets' is selected, CTC (Coating Thickness Correction) is displayed

	Key selection		Display
3.		Selection of the lining type.	
4.		The selected lining type is displayed.	flashing 
5.		Selecting the lining type <b>without</b> installed steel sheets.	flashin 
6.		Selecting the lining type <b>with</b> installed steel sheets.	flashing 
7.		The lining type is selected. 'CTC' is shown on the display when the lining type ' <b>with</b> installed steel sheets' was selected (Coating Thickness Correction).	
8.		The calibration mode is initialized. INF (infinite = ∞) is displayed provided the probe is lifted.	flashing 

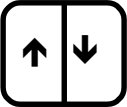
9. **Place the probe on the test drilling (reference position).**  
The reference position must be free from coating. In case of installed steel sheets between the bricks the probe must be moved over the surface until the lowest measuring value is displayed.

- |     |   |   |              |                              |
|-----|---|---|--------------|------------------------------|
| 10. |  | The measuring value at the reference position is taken over by the gauge. The probe can be lifted.    | flashing     | XX.X cm<br>APPL BATCH<br>CAL |
| 11. |  | Adjust to the calibration value, e.g. 10,5 cm.  | flashing     | 10,5 cm<br>APPL BATCH<br>CAL |
| 12. |  | The calibration value is logged to the memory. The calibration is completed.<br>[CAL] stops flashing. | not flashing | APPL BATCH<br>CAL            |

**Note:**

1. The existing calibration in the ZONE-SECTION mode is replaced by a new calibration or can be deleted by pressing CAL and CLEAR subsequently.
2. The calibration being completed the gauge always measures precisely provided that the probe is placed on the bricks (material in layer).
3. Due to the measuring technique, irritating measuring values can be displayed which do not represent the distance to the measuring reflector provided the probe is placed on the surface.
4. Switching the gauge off and on does not delete the calibration.

**8.6 Measurement**

The calibration being completed measurements can be taken.  
The probe is lifted from the measuring objects.

1. The requested ZONE (APPL)-Section memory and the lining type are already set (see 7.3 and 7.4).

Key selection

Display

- |    |  |  |                                 |
|----|--|--|---------------------------------|
| 2. |   | [- - - - cm] appears flashing on the display | - - - - cm<br>APPL BATCH<br>CAL |
| 3. | <b>Place the probe on the surface.</b><br>The residuary brick e.g. 12,5 cm is displayed.<br>Depending on the residuary brick thickness an analog bar of corresponding length is displayed. <u>In case of installed steel sheets between the bricks the probe must be moved over the surface until the lowest measuring value is displayed.</u> |  | 12,5 cm<br>APPL BATCH<br>CAL    |

4.  The measuring value displayed is logged to the memory provided the probe is placed on the bricks. The measuring value is printed provided that a printer is connected to the gauge.



12.5 cm  
APPL BATCH  
CAL

5. **Start the next measurement at step 2**  
**Press START**

**Note:** Closure shims

In case an unexpectedly low measuring value is displayed, the probe can be positioned near or above a closer shim. The measuring value displayed is false. The measurement should be repeated in a distance of at least 0,5m from the closer shim.

**8.7 Deleting the last measurement**



If a faulty reading was logged to the memory by pressing the START/SAVE key accidentally, this measuring value can be deleted immediately by pressing the CLEAR key.  
A short bleep confirms the last registered value has been deleted.



cm  
APPL BATCH

**8.8 Deleting calibration and activating the standard calibration**

The standard calibration is not appropriate for the thickness measurement of bricks or other materials in layers. The standard calibration serves only to air-measure the distance to a metal reflector of >1m x >1m.

**Deleting within a ZONE memory**

Key selection





Display

1.  Switch on gauge if not yet switched on.

2.  The gauge switches to the ZONE-SECTION mode (APPL) "APPL" and the two number of the last selected ZONE-SECTION appear flashing on the display e.g. [ 4:1 ].

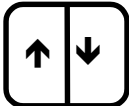
flashing 

4 : 1  
APPL BATCH

3.		Select the requested ZONE memory, e.g. [ 6:1 ].	flashing	6 : 1 APPL BATCH
4.		The gauge is switched to the ZONE-SECTION mode.		APPL BATCH
5.		The calibration mode is activated.	flashing	---- cm APPL BATCH CAL
6.		Press CLEAR. The standard calibration is activated.		APPL BATCH

### 8.9 Discontinuing calibration



If the CAL key is pressed once or twice by mistake, calibration is activated unintentionally.

Unintentionally activated calibration can be discontinued after the first or second pressure of the CAL key by switching the gauge off.

The former calibration remains unchanged.

### 8.10 Individual display and printing of statistical values

Provided the data printer MINIPRINT 4100 is connected to the gauge and switched on (ON-LINE) (see "12. Data printer"), the statistical values of the selected ZONE-SECTION memory are displayed after key stroke and printed simultaneously.

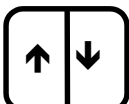
Key selection		Display		
2.		Switch on gauge if not yet switched on.		
2.		The gauge switches to the ZONE-SECTION mode (APPL) "APPL" and the two numbers of the last selected ZONE-SECTION appear flashing on the display., e.g. [ 4:1 ].	flashing	4 : 1 APPL BATCH
3.		Select the requested ZONE memory, e.g. [ 6:1 ].	flashing	6 : 1 APPL BATCH

4.  Confirm the selected ZONE memory, e.g.[ **6:1** ].





Having selected the ZONE memory column, the requested SECTION is adjusted.

6.  BATCH and the two numbers of the last selected ZONE-SECTION e.g. [ **6:1** ].

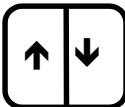
flashing 

7.  Adjust the selected SECTION memory, e.g. [ **6:2** ]

flashing 

8.  Confirm the adjusted SECTION memory [ **6:2**].



9.  **N** : number of measuring values

10.  **MEAN** : mean

11.  **STD.DEV.** : standard deviation

12.  **KVAR** : variation coefficient (STD.DEV / MEAN)

13.  **MAX** : highest single value

14.  **MIN** : lowest single value











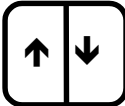

Press START/SAVE to stop the statistics and take the next reading.

**Note:**

The statistical values can be called in whenever you choose, even after each stored measurement.

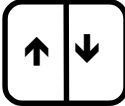
**8.10 Printing all single and statistical values**

Provided the data printer MINIPRINT 4100 is connected to the gauge and switched on (ON-LINE) (see "12. Data printer"), all statistical values are printed.

	Key selection		Display
1.		Switch on gauge if not yet switched on.	
2.		The gauge switches to the ZONE-SECTION mode (APPL). "APPL" and the two numbers of the last selected ZONE-SECTION appear flashing on the display, e.g. [ 4:1 ].	flashing 
3.		Select the requested ZONE-memory, e.g. [ 6:1 ].	flashing 
4.		Confirm the selected ZONE memory [ 6:1 ].	
Having selected the ZONE memory column the requested SECTION is adjusted.			
5.		BATCH and the two numbers of the last selected ZONE-SECTION appear flashing on the display, e.g. [ 6:1 ].	flashing 
6.		Adjust the requested SECTION memory, e.g. [ 6:2 ].	flashing 
7.		Confirm the selected SECTION-memory [ 6:2 ].	
8.		Press PRINT ALL. The statistical values are printed out with indication of date, time and the probe type which is actually	

connected to the gauge.

The following example shows the structure of print-out on the data printer MINIPRINT 4100 in the ZONE-SECTION mode:

ELEKTRO-PHYSIK STATS. PROGRAM	
26-NOV-96 11:51	
Probe F300ST	
APPL. No.	1
BATCH No.	1
26-Nov-96 15:10	
1	18,6 cm
2	21,4 cm
3	21,5 cm
4	21,4 cm
5	21,4 cm
6	21,4 cm
7	21,4 cm
8	21,4 cm
9	21,4 cm
10	21,4 cm
STATISTICS	
N-Val	10
Mean	21.1 cm
St.D	0.89 cm
Kvar	4.2 %
Max	21.5 cm
Min	18.6 cm

*date and time of print out*

*probe type connected to the gauge*

*selected zone memory*

*selected section memory*

*Date and time of the first reading taken in  
the ZONE-SECTION memory 1:1*

*single values*

*(max. 10.000 single values can be stored in all series of  
measurement)*

*(max 500 series of measurement can be stored)*

*statistics calculated from all measuring values*

*number of measuring values*

*mean*

*standard deviation*











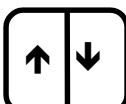

*variation coefficient*

*highest single value*

*lowest single value*

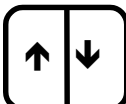
## 8.12 Total statistic in SECTION 99 of a ZONE memory column with print out of all single values

Provided the data printer MINIPRINT 4100 is connected to the gauge and switched on (ON-LINE) (see "12. Data printer"), all statistical values are printed.

	Key selection		Display
1.		Switch on gauge if not yet switched on.	
2.		The gauge switches to the ZONE-SECTION (APPL). "APPL" and the two numbers of the last selected ZONE-SECTION appear flashing on the display, e.g. [ 4:1 ].	flashing 
3.		Select the requested ZONE-memory, e.g.[ 6:1 ].	flashing 
4.		Confirm the selected ZONE memory[ 6:1 ].	
Having selected the ZONE memory column, the requested SECTION is adjusted.			
5.		BATCH and the two numbers of the last selected ZONE-SECTION appear flashing on the display, e.g. [ 6:1 ].	flashing 
6.		Adjust to the requested SECTION memory no. 99 [ 6:99 ].	flashing 
7.		Confirm the selected SECTION memory [ 6:99 ].	
8.		Press PRINT ALL. A total statistic comprising all sections within one ZONE memory column is printed with all single values.	

The following example shows the structure of a print out comprising all sections within one ZONE memory column in the ZONE-SECTION mode with the data printer MINIPRINT 4100 :

ELEKTRO-PHYSIK STATS. PROGRAM	
26-NOV-96 11:51	
Probe F300ST	
APPL. No. 1	
BATCH No. 99	
1	18,6 cm
2	21,4 cm
3	21,5 cm
4	21,4 cm
5	21,4 cm
6	21,4 cm
7	21,4 cm
8	21,4 cm
9	21,4 cm
10	21,4 cm
11	21,8 cm
12	21,9 cm
13	22,1 cm
14	21,9 cm
15	21,8 cm
STATISTICS	
N-Val	15
Mean	21.1 cm
St.D	0.89 cm
Kvar	4.2 %
Max	21.5 cm
Min	18.6 cm

*date and time of print out*

*probe type connected to the gauge*

*selected zone memory*

*selected sum of all measuring values in all section*

*single values*

*(max. 10.000 single values can be stored in all series of measurement)*

*(max 500 series of measurement can be stored)*

*statistics calculated from all measuring values*

*number of measuring values*

*mean*

*standard deviation*

*variation coefficient*



*highest single value*

*lowest single value*

### 8.13 Printing ZONE-SECTION memory allocation and number of stored measuring values (Directory)

If the data printer MINIPRINT 4100 is connected to the gauge and switched on (ON-LINE) (see "12. Data printer"), the contents can be printed.









Key selection

1. 
2.   Press ZONE and hold down, then press ON and hold both keys down.
3. The list which is now printed, indicates which ZONE-SECTION memories are occupied as well as the number of measuring values which are stored in the individual SECTION memories.

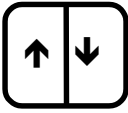







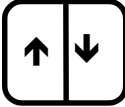

The following example shows the allocation of the ZONE-SECTION memories on a data printer MINIPRINT 4100 :

ELEKTRO-PHYSIK STRATOTEST-C Software V2.01		
Probe Codes: 80 A1 A3 BA		<i>Probes which can be connected to the gauge</i>
Appl-Batch Directory		<i>ZONE-SECTION directory</i>
APPL No. 1 Probe F300ST Code BA		<i>ZONE memory 1 initialised probe type F300ST</i>
BATCH No. 1 Number 3		<i>SECTION memory 1 occupied with 3 measuring values</i>
APPL No. 3 Probe 300ST Code BA		<i>ZONE memory 3 initialized probe type F300ST</i>
BATCH No. 1 Number 5		<i>SECTION memory 1 occupied with 5 measuring values</i>
BATCH No. 2 Number 3		<i>SECTION memory 2 occupied with 3 measuring values</i>
BATCH No. 3 Number 4		<i>SECTION memory 3 occupied with 4 measuring values</i>
END		<i>end of print out</i>

### 8.14 Deleting a series of readings with their statistical values in a ZONE-SECTION group

	Key selection		Display
1.		The requested ZONE memory column (APPL) is selected.	
2.		"BATCH" and the two numbers of the last selected ZONE-SECTION appear flashing on the display, e.g. [ 6:1 ].	flashing 
3.		Select the requested SECTION memory, e.g. [ 6:2 ].	flashing 
4.		The stored measuring series and the statistical values are deleted. A short bleep confirms the reading has been deleted.	flashing 
5.		The gauge remains in the SECTION memory which was deleted previously, e.g. [ 6:2 ].	

### 8.15 Deleting all measuring series including statistical and calibration values in one ZONE number

	Key selection		Display
1.		The gauge switches to the ZONE-SECTION (APPL). "APPL" and the two numbers of the last selected ZONE-SECTION appear flashing on the display, e.g. [ 4:1 ].	flashing 
2.		Select the requested ZONE-memory, e.g. [ 6:1 ].	flashing 
4.		Pressing the CLEAR key is confirmed by three beeps. Pressing ZONE at this point stops the deletion of all data in case this procedure was activated unintentionally.	flashing 
5.		All stored measuring series and statistical values including the calibration of the selected ZONE number are deleted. A long bleep confirms the reading has been deleted.	flashing 
6.		The gauge remains in the ZONE memory which was deleted previously, e.g. ZONE 6.	

## 8.16 Short instruction for measurements using the ZONE-SECTION mode











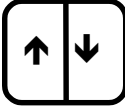

### Calibration, Measurement and Storage



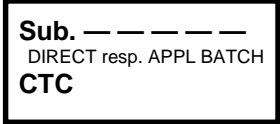

#### Calibration

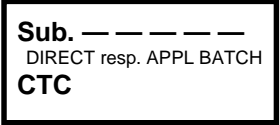
1. Determine the residuary thickness (calibration value) by means of a test drilling e.g. 13,2 cm.

Key selection

Display

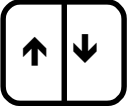
2.  Switch on gauge if not yet switched on.
3.  The gauge switches to the ZONE-SECTION (APPL). "APPL" and the two numbers of the last selected ZONE-SECTION appear flashing on the display, e.g. [ 4:1 ].  
flashing 
4.  Select the requested ZONE-memory, e.g. [ 6:1 ].  
flashing 
5.  Confirm the selected ZONE memory, e.g. [ 6:1 ].  

6.  Selection of the lining type.
7.  The selected lining type is displayed.  
flashing 
8.  Selecting the lining type **without** installed steel sheets.  
blinkt 
9.  Selecting the lining type **with** installed steel sheets.  

10.  The lining type is selected. 'CTC' is shown on the display when the lining type '**with** installed steel sheets' was selected (Coating Thickness Correction).
11.  The calibration mode is initialized. INF (infinite =  $\infty$ ) is displayed provided the probe is lifted.
12. **Place the probe on the reference position of the test drilling.**  
The reference position must be free from coating. In case of installed steel sheets between the bricks the probe must be moved over the surface until the lowest measuring value is displayed
11.  The measuring value at the reference position is taken over by the gauge. The probe can be lifted
12.  Adjust to the calibration value e.g. 13,2 cm.
13.  The calibration value is logged to the memory. The calibration is completed. [CAL] stops flashing.

cm  
DIRECT resp. APPL BATCH  
CTC

flashing  
---- cm  
APPL BATCH  
CAL

flashing  
XX.X cm  
APPL BATCH  
CAL



flashing  
13,2cm  
APPL BATCH  
CAL

not flashing  
13.2 cm  
APPL BATCH  
CAL

### Measurement

The calibration being completed, the gauge is ready to take measurements. The probe is lifted from the surface.

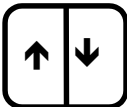

The ZONE is already set, now only the SECTION needs to be adjusted.

14.  "BATCH" and the two numbers of the last selected ZONE-SECTION appear flashing on the display, e.g. [ 6:1 ].
15.  Select the requested SECTION memory, e.g. [ 6:2 ].
16.  Confirm the selected SECTION memory [ 6:2 ].

flashing  
6 : 1  
APPL BATCH



flashing  
6 : 2  
APPL BATCH

APPL BATCH

17.  [- - - - cm] appears flashing on the display. 

18. **Place the probe on the coating-free surface.**  
The residuary brick thickness e.g. 12,5 cm is displayed. Depending on the residuary brick thickness an analog bar of corresponding length is displayed. In case of installed steel sheets between the bricks the probe must be moved over the surface until the lowest measuring value is displayed 

### Storage

21.  The displayed measuring value, e.g. 12,5 cm is logged to the memory, provided the probe is placed on the surface. 

21. Start again at step 14 to take the next measurement or select new SECTION (step 11).

## 9. Initial functions and basic gauge settings

The STRATOTEST 4100 C gauge include a number of functions that can only be called up or activated during start-up.

Function	Key combination
Total reset	INIT + CLEAR + ON
LCD segment test	↑-key + ON
Setting of time and date	CAL + ON
Set gauge options for: <ul style="list-style-type: none"> <li>• Automatically switch off</li> <li>• Key lock</li> <li>• Display illumination</li> <li>• Measuring unit</li> <li>• Acoustic signals</li> </ul>	INIT + ON

Table of initial functions and basic settings (see. 9.4)

### 9.1 TOTAL reset

A TOTAL reset is recommended,

- for deleting calibration and all measuring values;
- if all basic settings shall resume their original function '0' (see table "9.4 basic gauge settings");
- if gauge functions are blocked and can not be performed any more.

Switch off the gauge if necessary. Press CLEAR, INIT and ON subsequently and hold all keys down until a long bleep confirms the total reset.

## **9.2 LCD segment test**











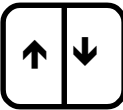

The LCD segment test enables all sections of the LC display to be inspected and checked.

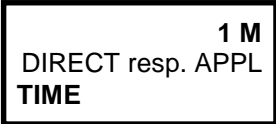
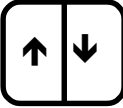
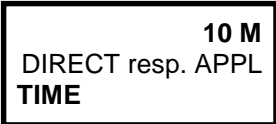

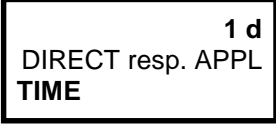
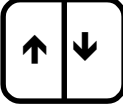
Switch off the gauge if necessary. Press  $\uparrow$  key and ON subsequently and hold both keys down as long as the segments should be checked.

### 9.3 Setting of date and time

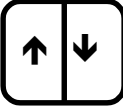
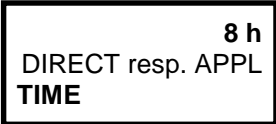
The gauge has a quartz-controlled timer which relays information to the MINIPRINT. The current date and time appear automatically on each print out of statistics.

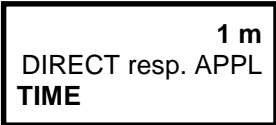
Time and date can be viewed on the display and if necessary adjusted:

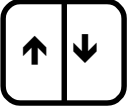
	Key selection		Display
1.	 	Switch off the gauge. Hold down CAL and press ON. Keep both keys depressed until you hear the bleep.	
2.		Select year e.g. 96.	flashing 
3.			flashing 
4.		Select month, e.g. October.	flashing 
5.			flashing 
6.		Select day, e.g. 7th.	flashing 
7.			flashing 
8.		Select hour e.g. 8 h.	flashing 
9.			flashing 

- 10  Select minute, e.g. 30. flashing 30 m  
DIRECT resp. APPL  
TIME
11.  Time is adjusted. cm  
DIRECT resp. APPL

#### 9.4 Basic gauge settings

Switch off the gauge. Hold down INIT and press ON. Keep both keys pressed until you hear the signal. The gauge will now display a pair of numbers, e.g. 1:0 or 1:1.

Press INIT to move through each of the table's functions from 1 to 5. Use the arrow keys to set the option 0 or 1.

**Table of basic settings**

INIT		Basic setting	
1	0	Automatic switch off	Automatic switch off after 3 minutes
	1		long term mode
2	0	Key lock function for CAL key and "zero calibration"	Off
	1		On
3	0	Display illumination	inactive
	1		active
4	0	Measuring unit	Metric / cm
	1		Imperial / inch
5	0	Acoustic signal	inactive
	1		active
In order to save the basic settings press INIT until 'cm' or 'inch' is displayed.			

**Note:**

The display illumination shortens the battery life considerably. It is thus recommended always to have a replacement battery at hand.









## 10. Calibration and measurement in special applications

### 10.1 Zero calibration

As a rule, "zero calibration" is not necessary when measuring rotary kilns. The "zero calibration" serves for correcting the geometry. Measurements on surfaces with a curvature radius less than 2m require a "zero calibration" (see 10.2). If a "zero calibration" is required, this calibration must in any case be performed on an uncoated metal reflector with the same curvature radius as the measuring object.

	Size of the metal reflector
30cm probe	larger than 1m x 1m
80cm probe	larger than 3m x 3m

Zero calibration can be performed for the DIRECT mode as well as for the ZONE-SECTION mode.

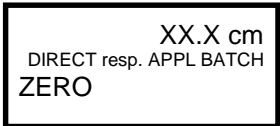
- | Key selection |   | Display  |
|---------------|---|--|
| 1.            |  <p>Switch on gauge if not yet switched on.</p>   |  |
| 2.            |  <p>or</p>  <p>Switch the gauge to the DIRECT or the ZONE-SECTION mode. DIRECT or APPL (and the last selected ZONE-SECTION-pair of numbers, e.g. [ 4:1 ] ) appear flashing on the display. Working in the ZONE-SECTION mode select the requested ZONE memory (see. 8.4)</p> | flashing  |
| 3.            |    |  |
| 4.            |  <p>Zero calibration mode is initialised.</p>  | flashing  |
| 5.            | <p>Place the probe on a metal reflector (&gt;1m x &gt;1m or &gt;3m x &gt;3m) with the necessary curvature radius.</p>   |  |
| 6.            |  <p>The zero value is taken over by the gauge. The probe can be lifted from the reflector.</p>   |           |

**Note:**

1. An existing calibration is replaced by a new calibration or can be deleted by pressing CAL and CLEAR subsequently.
2. Switching the gauge off and on does not delete the calibration.

## 11. Trouble shooting

The following list of error messages explains how to identify and eliminate faults. All error messages are marked by the letter "E" (E = Error)

### Faults that cause the gauge to switch off:

E01 Probe type incompatible.

E02 Probe not connected.

This message only appears when no probe is connected after a total reset.

E03 Probe defective.

This message only appears immediately after the gauge is switched on indicating that the probe needs to be repaired or if the probe becomes detached from the socket while in use.

E04 Battery voltage too low  
(insert new battery).

E11 Memory full (error message displayed for about 1.5 sec).

- The gauge does not switch off automatically (see 9.4 basic gauge settings, Automatic switch off).
- The gauge takes no further measurements or gives illogical readings - the quickest remedy is a total reset (see 9.1).
- The keyboard does not function properly, (see 9.4 Basic gauge settings, Key lock).

If the gauge cannot be switched off from the keyboard, remove the battery for a short time (2 min) for a total reset.

## 12. Data printer MINIPRINT 4100

The portable MINIPRINT 4100 is fitted with 4 built-in NiMH rechargeable batteries. The power pack supplied with the gauge is sufficient to run the printer and recharge the battery. A fully loaded rechargeable battery will last for several thousand lines of print. Loading time is approximately 14 hours. The battery state is indicated by two LED's. The red LED (low) indicates battery discharge. If the power pack is connected, the yellow LED (charge) indicates that the rechargeable batteries are being charged. As soon as the yellow LED goes off, battery charging is completed. The MINIPRINT 4100 is fitted with an internal charging control preventing the rechargeable battery from being discharged or overcharged.

A special power pack for quick loading which can be provided as an option allows quick loading of the NiMH rechargeable batteries within one hour.

The portable data printer MINIPRINT 4100 provides an instant print-out and documentation of the measuring values. Examples of print-outs in the DIRECT and the ZONE-SECTION mode, respectively, are given in chapter 3 of the operating manual.

The gauge and the printer can be connected by means of a plug-in connection and thus represent a practical measuring and documentation device.

The MINIPRINT 4100 printer will provide an instant or later print-out of:

- all single values.
- the corresponding ZONE-SECTION numbers.
- statistical values which were calculated from the measuring values of a ZONE-SECTION number.
- the directory (DIRECTORY), see 8.12.

### Operating the data printer

1. Plug the printer in the lateral printer socket of the thickness gauge STRATOTEST.
2. Switch on STRATOTEST gauge
3. Switch MINIPRINT 4100 to the necessary operation mode (ON / OFF) .

#### Note:

1. The STRATOTEST functions are blocked as long as printing is in progress.
2. The printer will stop working if OFF is pressed (green LED goes off).
3. As the printer only requires power while it is printing out, it need not be switched off when not in use.
4. When the STRATOTEST switches itself off automatically, the printer status -either ON or OFF- will remain in memory. When the gauge is switched on again the printer will resume its previous status.
5. The paper feed (FEED) does not function unless both the STRATOTEST and MINIPRINT are switched on.

### **12.1 Changing the paper roll**

1. The STRATOTEST and the MINIPRINT should be connected.
2. Switch on the STRATOTEST.
3. Activate the MINIPRINT by pressing ON / OFF-key (green LED lights up).
4. Press FEED to remove any remaining paper.
5. Remove Plexiglas slider from printer.
6. Remove empty paper roll and insert new one.
7. Cut off the end of the new roll cleanly and insert the end into the slit at the bottom while pressing FEED.
8. The printer mechanism will now draw the paper through.
9. Press FEED until the end of paper strip comes out.
10. Draw out paper for approx. 4" and insert into the Plexiglas cover.
11. Keep paper end at Plexiglas slider and insert Plexiglas cover again.

### **12.2 Changing the printer ribbon**

As the printer ribbon is mounted as a loop in a plastic cartridge, it can easily be removed from the printer.

1. Remove Plexiglas slider from printer.
2. Now draw the paper strip out of the printer.
3. Locate the point on the right marked „PUSH“ and press. This releases the other end of the cartridge from the cog pin.
4. The cartridge may now be removed without difficulty. A new cartridge can be inserted by reversing the instructions above.
5. Tighten the ribbon by turning the notched knob of the new cartridge in the direction of the arrow.
6. Tilting the cartridge slightly, slip it over the cog pin.
7. Clip in the other end, making sure that the ribbon is taut and fed horizontally into the paper slot.
8. Now insert paper as described under 12.1.

### 12.3 Quick loading function for NiMH rechargeable batteries

For quick loading with the optional charger remove NiMH rechargeable batteries from the MINIPRINT 4100. Insert batteries into power pack. The MINIPRINT is fitted with a set of four NiCd rechargeable batteries. Two of them are located in the battery case on the back of the printer, the others are located under the paper roll.

1. Put the printer with the front panel on a base.
2. Use a screw driver for recessed-head screws to loosen the screws of the battery casing.
3. Lift cover of battery casing.
4. Remove NiMH rechargeable batteries.
5. To remove the two other batteries remove the Plexiglas slider.
6. Remove paper roll from its casing. It is not necessary to remove the paper from printing mechanism.
7. Push the side panels of the paper roll casing to lift the casing. Remove battery support from casing to take out the NiMH rechargeable batteries.
8. Insert the 4 NiMH rechargeable batteries into the quick loading power pack for recharging.
9. After battery charging has been completed place the batteries again into battery support and insert it into the battery casing. Then carry out instructions 1-8 in reverse order.

Caution:

Please observe the right polarity when inserting the batteries.

### 12.4 Printer self test

The MINIPRINT 4100 features a printer self-test function.

1. Connect MINIPRINT 4100 to the STRATOTEST gauge. Then switch on the STRATOTEST gauge..
2. Press ON/OFF key until the green LED goes off.
3. Keep FEED key pressed down, then press ON/OFF key.
4. Deactivate  
Press ON/OFF.

## 13. Connecting a PC (IBM and compatible)

The STRATOTEST 4100 C gauge has a combination interface RS232C. The connecting cable and the data transfer program can be used to transfer all readings and statistics to a PC for further processing. The data transfer procedure is the same as that for data print-out.

## 14. Technical data

Measuring technique:	Eddy current principle	
Measurable layers:	All non-metal materials used in civil engineering and building activities like refractory bricks, bituminous mixes, Portland blast furnace cement, timber, concrete without reinforcement etc.	
Reflectors:	iron, aluminium or materials with similar electrical conductivity	
Probe type:	F300ST	F800ST
Measuring range:	0...30 cm	0...80 cm
Resolution:	0,01cm for measuring values lower than 5 cm	
	0,02cm for measuring values lower than 10 cm	0,2cm for the whole measuring range
	0,1cm for measuring values higher than 10 cm	
Measuring object:	flat and concave or convex surfaces	
min. substrate thickness:	0,3mm	0,3mm
guaranteed tolerance:	$\pm(0,5 \text{ cm} + 3 \% \text{ of reading})$	$\pm(1,0\text{cm} + 3 \% \text{ of reading})$
display:	digital on LC display and print out	
illumination:	operator selectable	
storage capacity:	DIRECT mode: statistical values	
	ZONE-SECTION mode: 10.000 single values in about 500 measuring series	
Power supply:	1 x 9 Volt Alkaline battery or rechargeable batteries	
Battery life:	approx. 20 hours with one battery (without illumination); approx. 2 hours with one battery (with illumination)	
Ambient temperature:	Gauge: 0°...50° C, Probe: 0°...70° C	

Technical specifications subject to change

**ElektroPhysik**

Dr. E. Steingroever GmbH & Co. KG  
Pasteurstr. 15, D 50735 Köln

Telefon 0221 / 752040, Telefax 0221 / 7520467

[www.elektrophysik.com](http://www.elektrophysik.com)

[info@elektrophysik.com](mailto:info@elektrophysik.com)